

Printed Habitats: Integrating Wildlife Into Urban Facades

Project MA / SS 2025

Professorship Digital Fabrication
Prof. Dr. Kathrin Dörfler / Iuliia Larikova, M.A.

with a support of
Chair of Terrestrial Ecology
Prof. Dr. Wolfgang Weisser/ Dr. Fabio Sweet

Introduction

This interdisciplinary design studio explored the future of sustainable renovation through the integration of wildlife into urban facades. Positioned at the intersection of digital fabrication, urban ecology, and architectural design, the course invited students to rethink facades as habitats—not only for humans, but also for selected animal species.

Students developed multiscale design proposals for replicable applications in Ingolstadt. The main case study focused on a multifunctional façade for the upper part of the historic Water Tower in Ingolstadt. Using computational tools and 3D printing technologies, the goal was to create architectural solutions that addressed both ecological and human needs. The course applied Animal Aided Design principles, considered preservation constraints, and leveraged ceramic extrusion 3D printing to design and fabricate components for site-specific implementation. Topics included species behavior and habitat requirements, climate analysis, integration within the historical context, and additive manufacturing strategies using ceramic materials.

Through a series of design sessions and fabrication explorations, students investigated how digital tools and ecological parameters could be combined to shape an architecture of coexistence. A dedicated workshop at the Design Factory enabled participants to engage directly with the site, testing early concepts through prototyping. Final outcomes included comprehensive design studies, a selected full-scale (1:1) prototype tailored to the Water Tower in Ingolstadt, and a concept for the urban multiplication of the project.

Project MA / SS 2025 / Technical University of Munich

Teaching

Professorship of Digital Fabrication

Prof. Dr. Kathrin Dörfler, Iuliia Larikova, M.A.

with a support from

Chair of Terrestrial Ecology

Prof. Wolfgang Weisser, Dr. Fabio Sweet

In collaboration with

City of Ingolstadt (Thomas Schneider)

Tonality GmbH



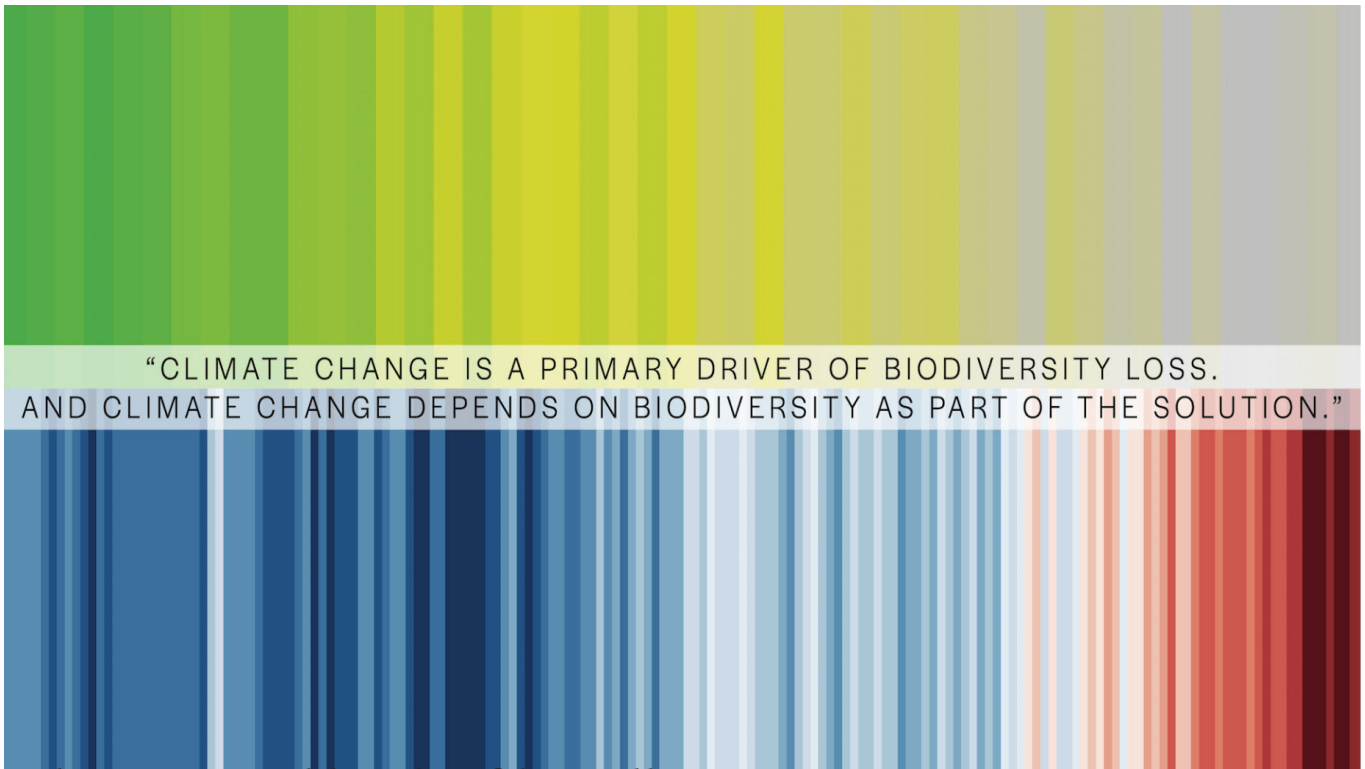

“CLIMATE CHANGE IS A PRIMARY DRIVER OF BIODIVERSITY LOSS. AND CLIMATE CHANGE DEPENDS ON BIODIVERSITY AS PART OF THE SOLUTION.”

Biodiversity extinction and climate change @thesustainableagency.com

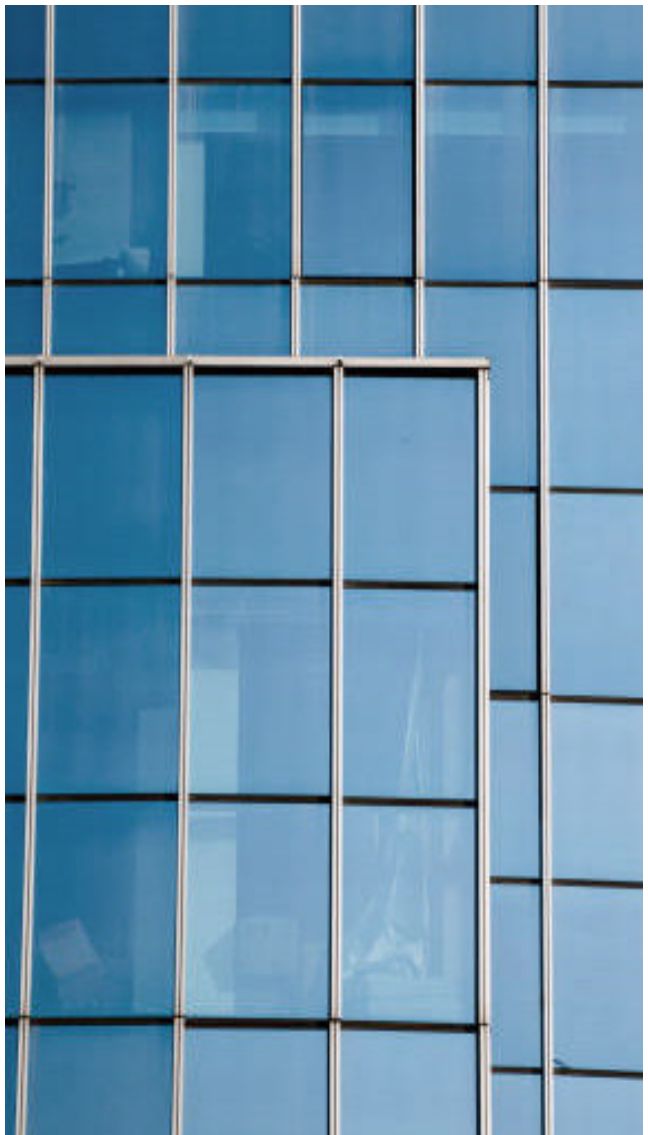

Palazzo Rucellai(left) and modern office building the glazed facade (right)

Rethinking Digital Technologies: Beyond the Anthropocene

The loss of biodiversity, on a par with climate change, poses a serious threat to our ecosystems. Over the past 50 years, global wildlife populations have declined by an average of 73% (Living Planet Report 2024). This development is closely linked to the anthropocentric orientation of technology and architecture over the past century. Addressing the climate and biodiversity crises requires a fundamental rethinking of human-animal coexistence. The European renovation way, aimed at improving the energy efficiency of building, offers both opportunities and risks: millions of buildings are set to be retrofitted. However, if existing animal habitats within building envelopes are overlooked, this could accelerate species loss.

To counter this problem, we are developing a new, digitally supported, approach towards design of the building envelopes: using digital technologies, nesting and shelter elements for small animals such as hedgehogs and bats, as well as for various bird species, are integrated into building envelope, while also considering climatic parameters.

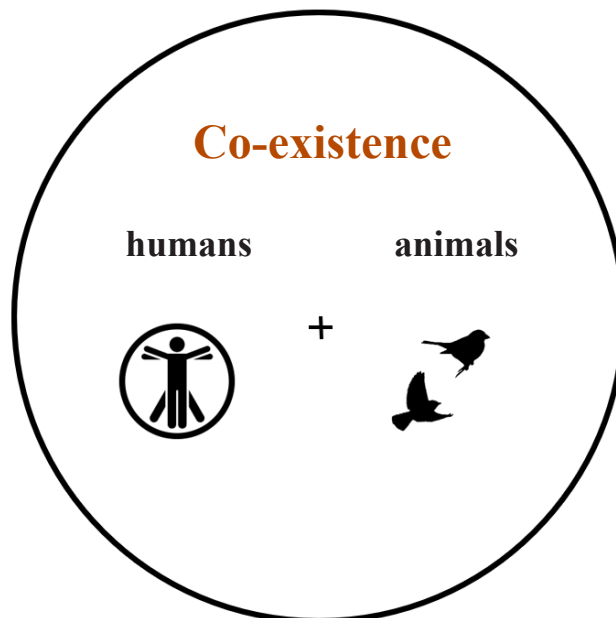

Human-Animal Co-existence @Iuliia Larikova



3D Printing Process in the laboratory conditions @Tizian Rein



Post-processing of the 3D printed elements@Tizian Rein

Additive Manufacturing with clay

The digitally optimized façade elements are then produced using a 3D printing technology: additive manufacturing with clay-based materials. This fabrication method enables a high degree of geometric freedom, allowing each element to be custom shaped according to its microclimatic and ecological function: whether to provide shading, channel rainwater, or offer habitat niches for targeted species. The use of a robot arm connected to the extrusion system, equipped with an extruder and a continuous material feeding system, ensures both precision and efficiency in the printing process. By adjusting parameters such as print speed, layer height, and extrusion rate, the process can be fine-tuned to balance form complexity with structural stability.

Compared to conventional production methods, this approach minimizes material waste, reduces manual labor, and supports on-demand, decentralized fabrication. Moreover, the parametric design-to-production workflow allows for the integration of climate data, biodiversity needs, and structural performance into a seamless digital production chain.

In this way, the upcoming renovation wave can be shaped not only to meet energy-efficiency targets but also to actively contribute to urban biodiversity and climate resilience, turning façades into multifunctional, living surfaces.

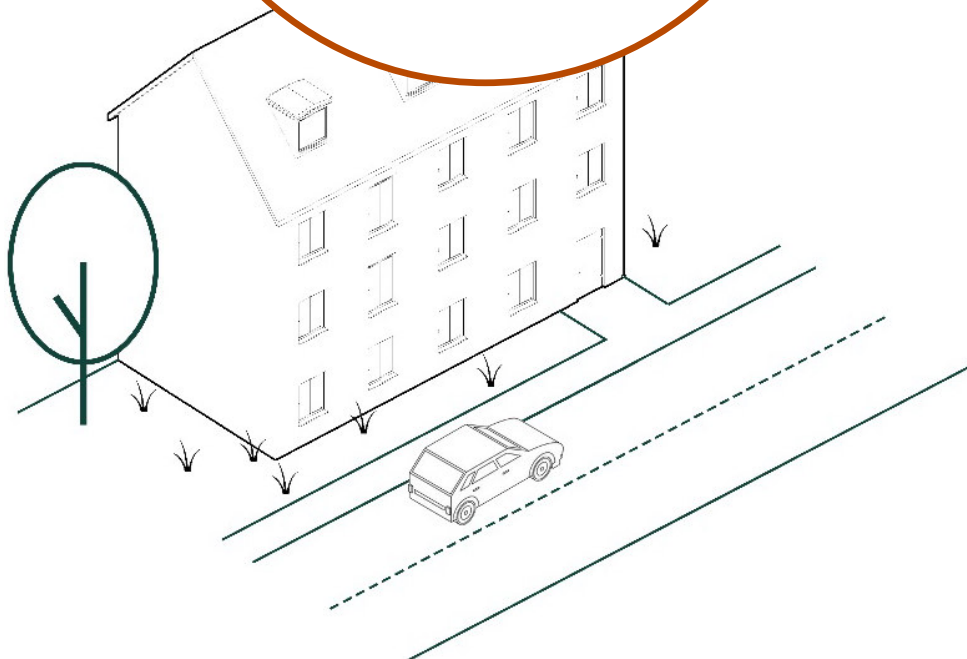
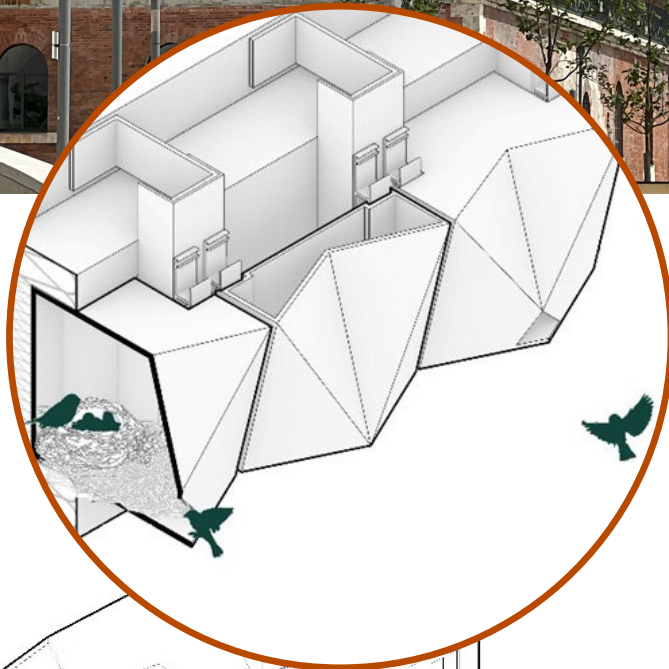

*Ingokstadt Tower (upper picture) @Michelle Mattes, Sacha Rahem, Ambroise Salles, Anne Schlumbohm
Nest facade(in the middle), Building for the studies (lower picture) @Iuliia Larikova*

Building Site

Dalwigk Tower:

The water tower is part of the historic fortress Kavalier Dalwigk and was added to the structure in 1916/1917. After a major renovation in 2016, the entire ensemble was repurposed as the digital start-up center brigk. The upper section of the tower, originally used as a water reservoir, now stands unused, its façades clad in plain gypsum.

We see this as an opportunity to reimagine the tower as a contemporary landmark. Through the development of a 3D-printed façade that supports urban biodiversity, we aim to demonstrate the potential of digital technologies for the sustainable transformation of the city

Urban Multiplication:

Ingolstadt is one of the first German cities to develop a detailed urban digital twin at Level of Detail (LOD) 3. This creates a unique opportunity to apply digital technologies at the urban scale to identify strategies for integrating biodiversity into the built environment.

As part of the studio project, students were asked to analyze the city model, identify potential intervention sites, and test their digital planning approach on a selected building.



Ingolstadt city plan @Lisa Clausen-Schaumann, Marie Valerie Krudl, Cederik Mulkers

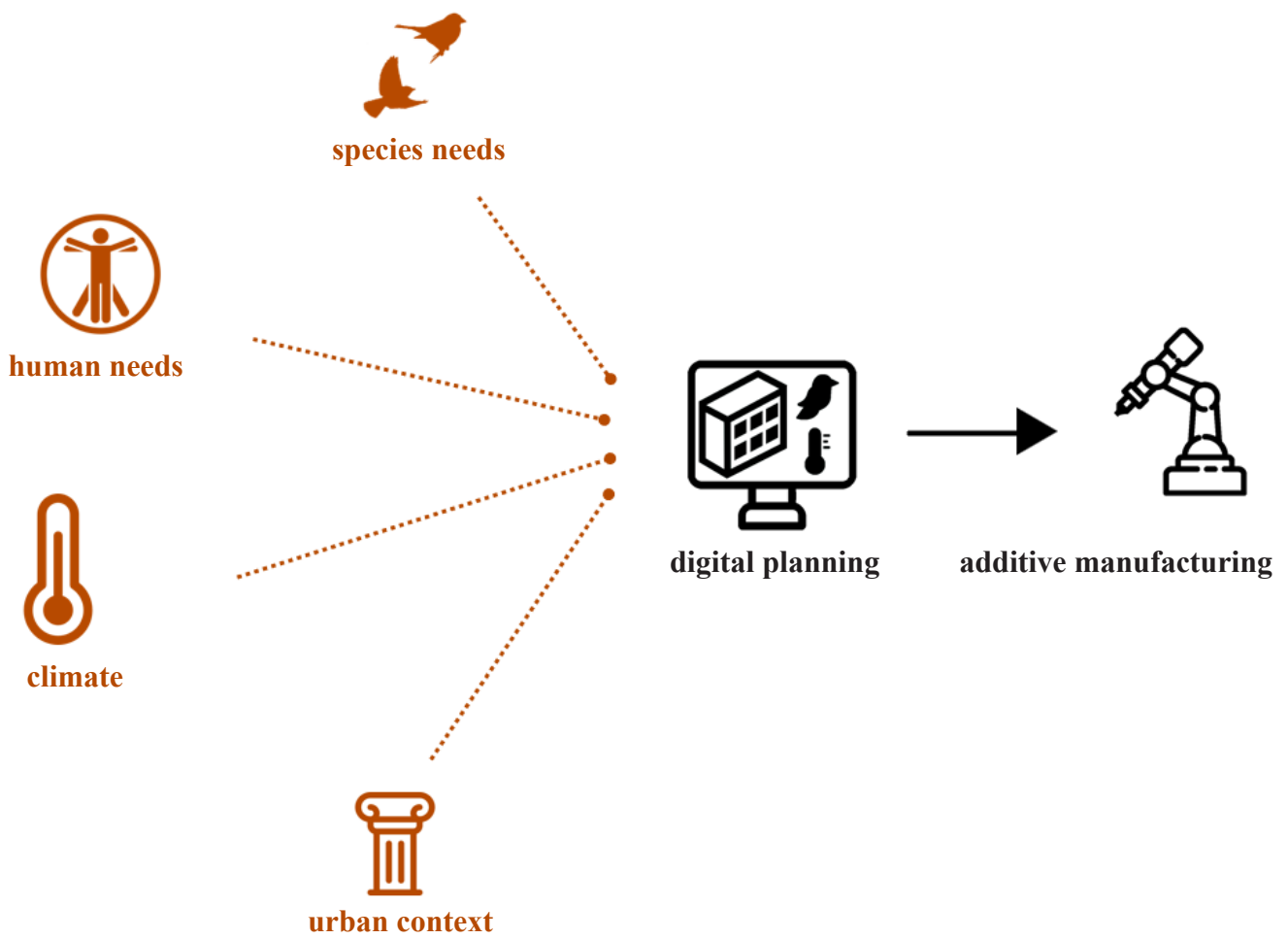

Digital Planning Technologies and Additive Manufacturing as Catalysts for an Interdisciplinary Multi-parametric Approach

Design Task

Working across multiple scales, from species-specific habitat modules to façade systems and urban replication strategies, participants explored how digital design and additive manufacturing can shape an architecture of coexistence. The studio drew on principles of Animal Aided Design, combining ecological knowledge with generative design tools and parametric modeling techniques. A particular emphasis was placed on site-specific adaptation, climatic analysis, and the spatial requirements of selected animal species.

Leveraging robotic ceramic 3D printing, students translated their digital concepts into manufacturable prototypes. The ceramic extrusion process enabled the development of performative, resource-efficient components tailored to local environmental and heritage constraints. Through iterative prototyping and material experimentation, participants examined how form, porosity, and surface articulation can foster microhabitats while contributing to thermal regulation and shading.

A key part of the process involved a workshop at the Design Factory and on-site explorations, where design hypotheses were tested at 1:1 scale and further informed by the material behavior of clay-based composites. Final outcomes included detailed design studies, digital fabrication files, and a full-scale prototype developed for the Water Tower, accompanied by speculative proposals for scalable implementation throughout the city.

This studio posed critical questions: How can digital technologies help mediate the coexistence of human and non-human species in the built environment? What spatial and material strategies are required to embed biodiversity into future renovation and densification projects? And how can digital technologies become a systemic contributor to ecological resilience at both building and urban scales?

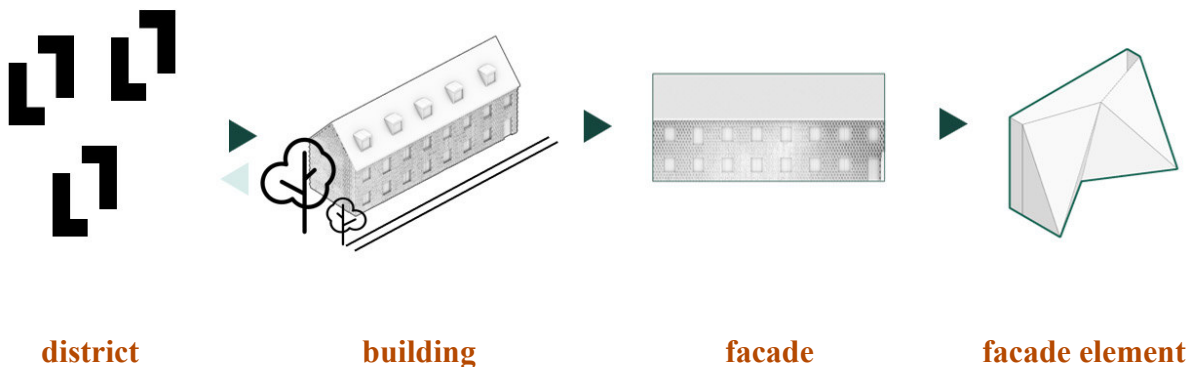

studio focus

Multiscale Design Approach: from a district to a 3D printed facade element @Juliia Larikova

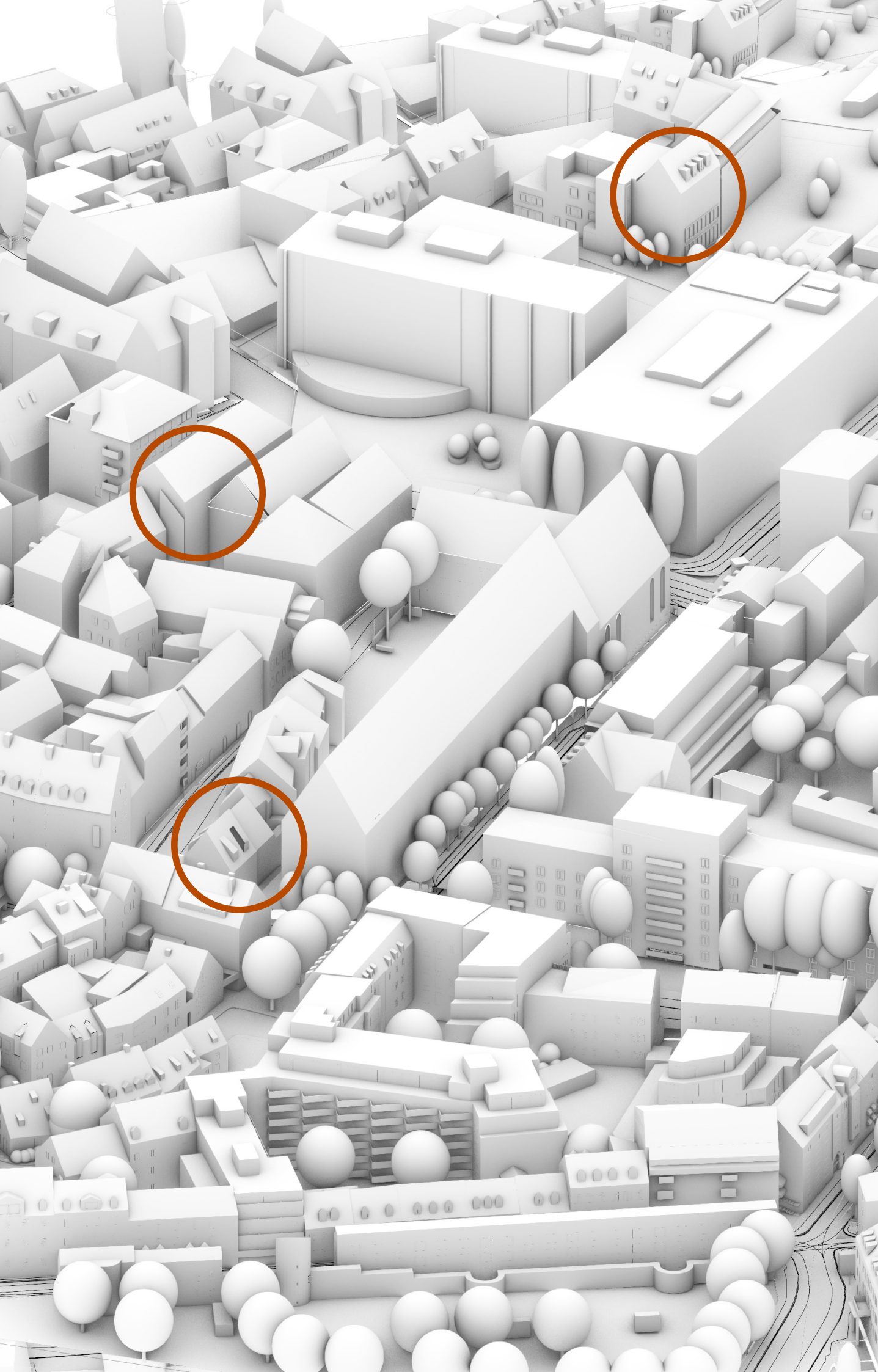

Urban Multiplication

To better understand the more-than-human approach and to verify the reproducibility of the design, part of the task involved analyzing the city center of Ingolstadt with a focus on targeted species and applying a design concept to selected buildings. The goal was to demonstrate that biodiversity-inclusive design, when combined with digital technologies, holds potential not only for specific sites but also for broader application at the urban scale and replication across multiple projects. Digital technologies thus enable smart analysis, integrated planning, and a seamless design-to-production workflow. Supported by climate simulations, this methodology strategically and systematically enhances biodiversity while also contributing to the mitigation of climatic impacts.



Design Projects

Swallow-Aided-Design

Where swallows nest, fortune rests.

Introduction

Project title: Swallow-Aided-Design - Where swallows nest, fortune rests.

Group members: Lukas Litterst, Alissa Schulteß, Giulia Stallwanger, Leoni Tomečko

Project description: This project is developing a modular façade system that supports the coexistence of humans and swallows in urban areas. Based on the animal-aided design approach, parameterized façade elements are designed that not only meet the species-specific requirements of the birds, but also take into account climatic conditions such as solar radiation.

These elements are designed for 3D printing with clay - a sustainable material with an ecological impact. Such a specific application is the façade design for the Dalwigktower in Ingolstadt. It blends homogeneous with the existing building and can be seen as a visible sign of future-oriented, biodiversity-driven construction.

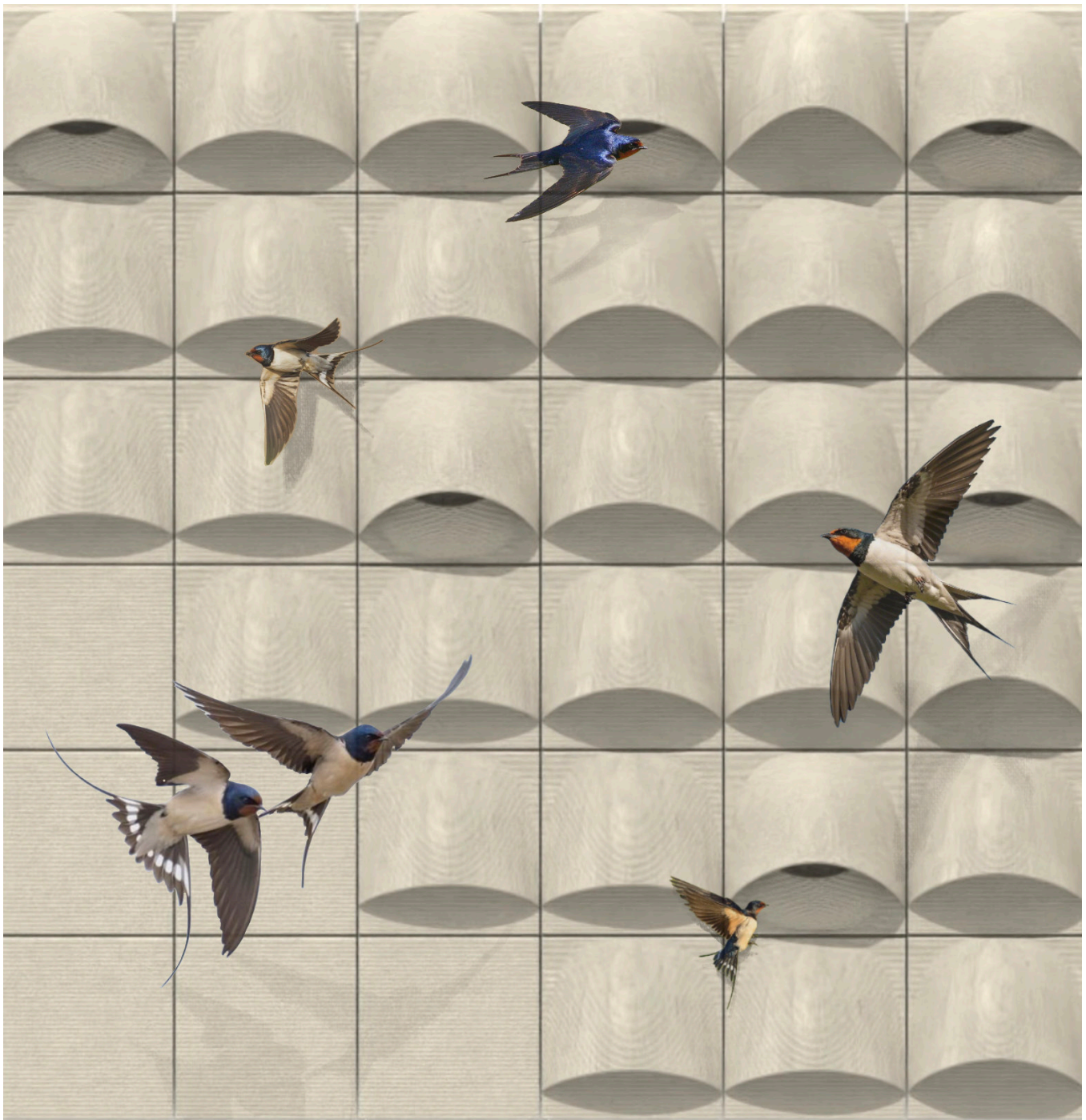

Collage of the future vision of a swallow-friendly façade

Species Portrait

House Martin

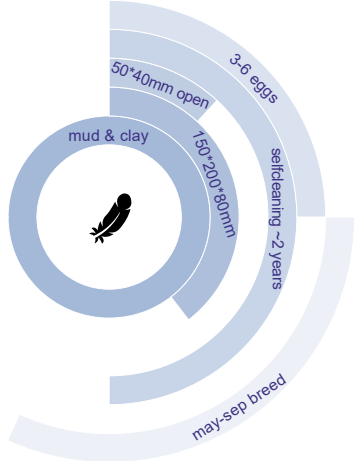
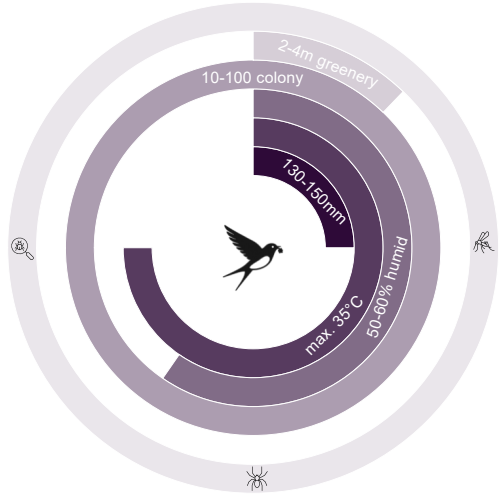
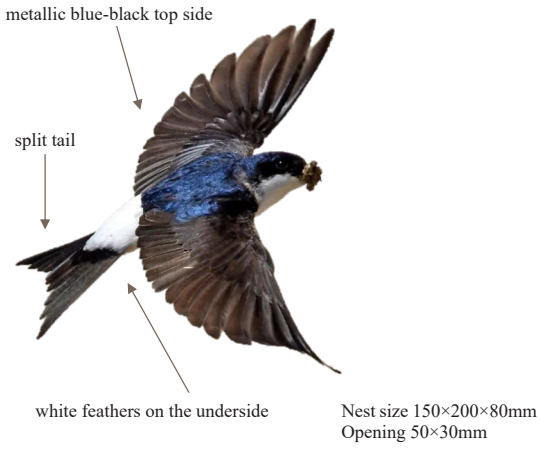

Barn Swallow

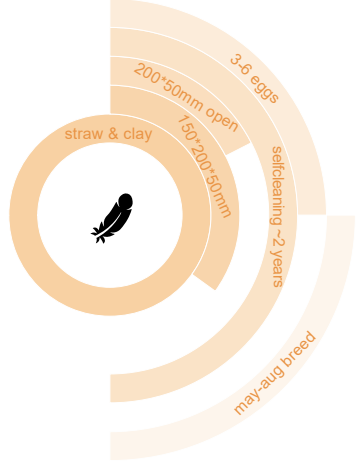
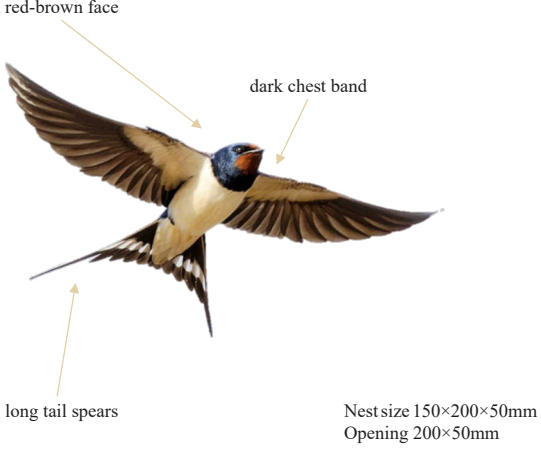

Swallow-Aided-Design

Where swallows nest, fortune rests.

Design Concept



1. bowl-/ domeshaped form for nest
2. nest opening sizes for two species
3. overhang for rain and sun protection
4. rough surface/texture - grip
5. choice of color (light beige) - acceptance of nest



Collage of the future vision of a swallows inhabiting the façade

Swallow-Aided-Design

Where swallows nest, fortune rests.

Final Design

Barn Swallow

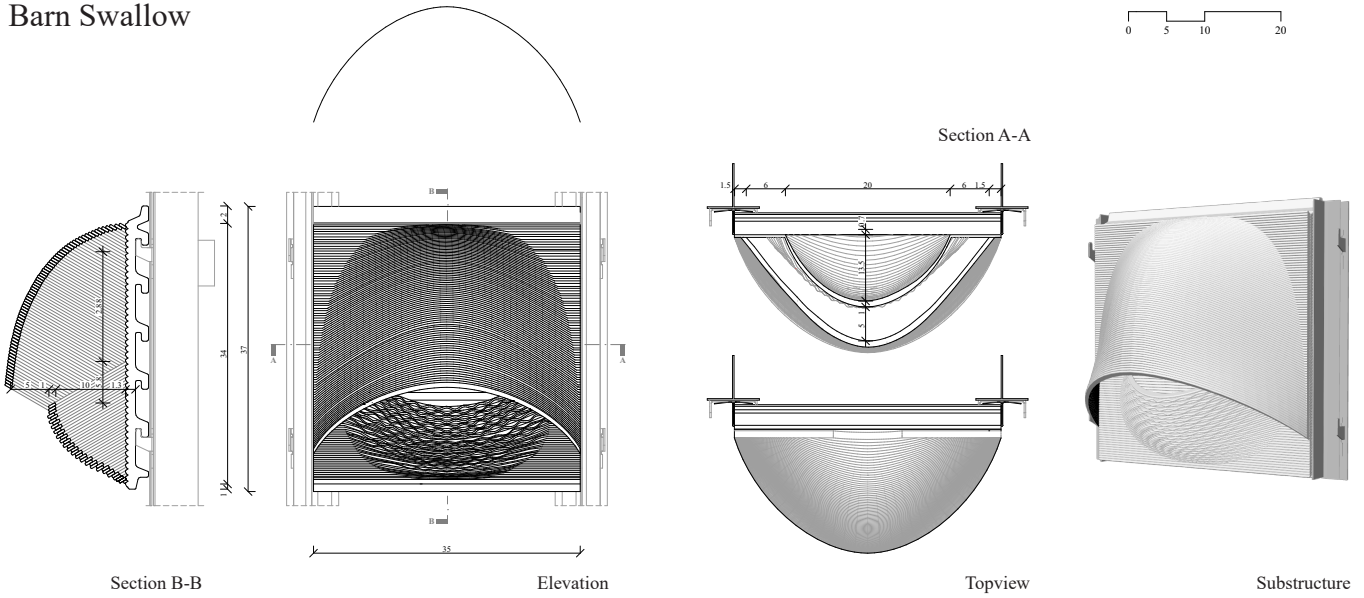

House Martin



Selfnisting



Climate I

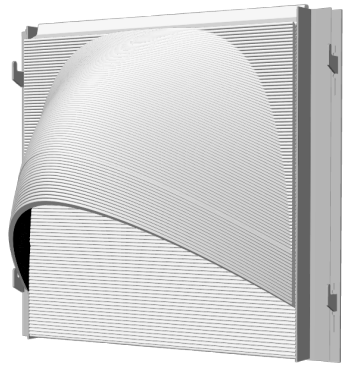

Climate II

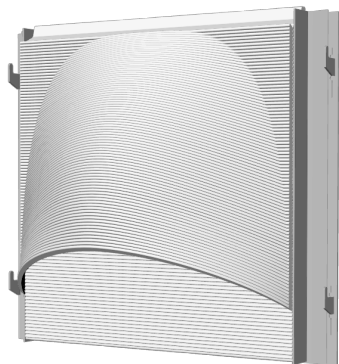

Climate III

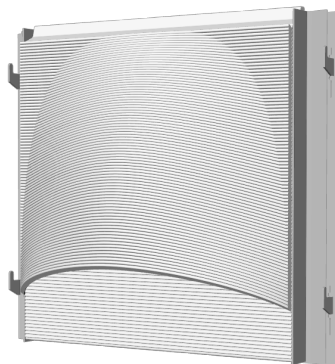

Standard

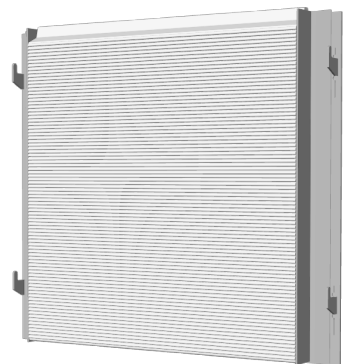

Selection of parametric façade elements

Dalwigk Tower, Ingolstadt



Visualisation Zoom-In Dalwigk Tower, Ingolstadt

Swallow-Aided-Design

Where swallows nest, fortune rests.

Final Design

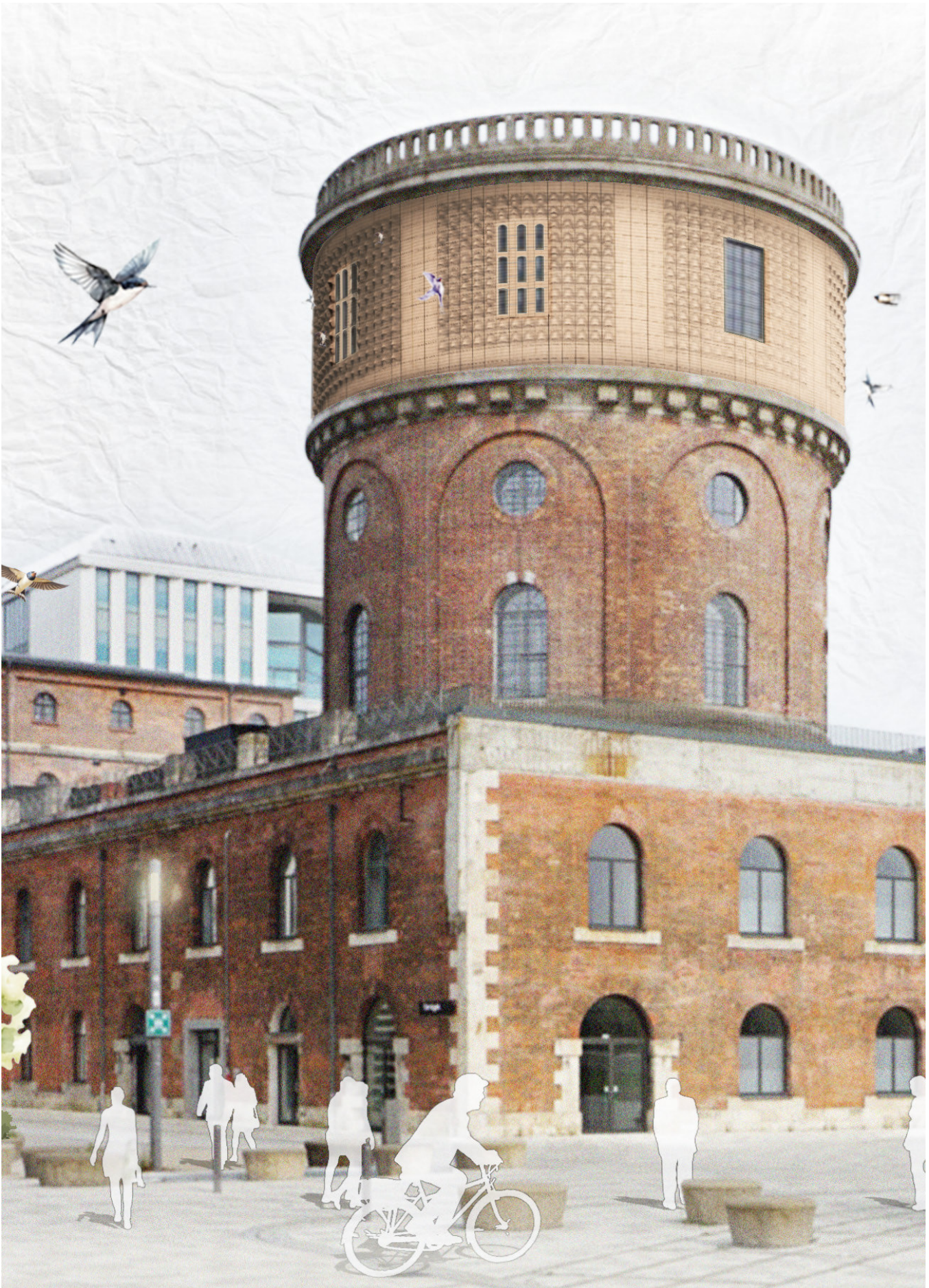

Visualisation of Dalwigk Tower, North-West façade

Parametric Design

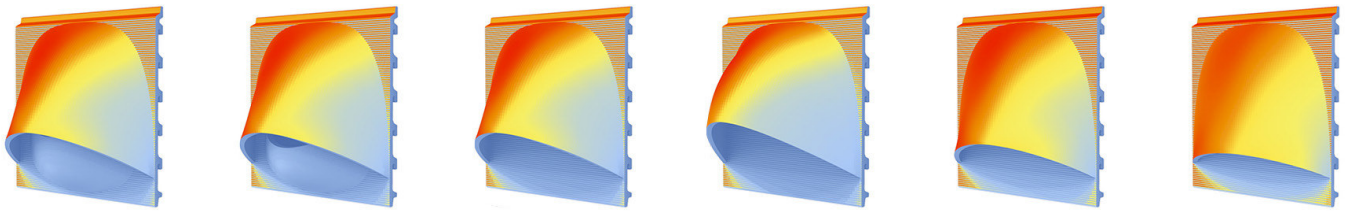

Climate analysis: sun for façade elements

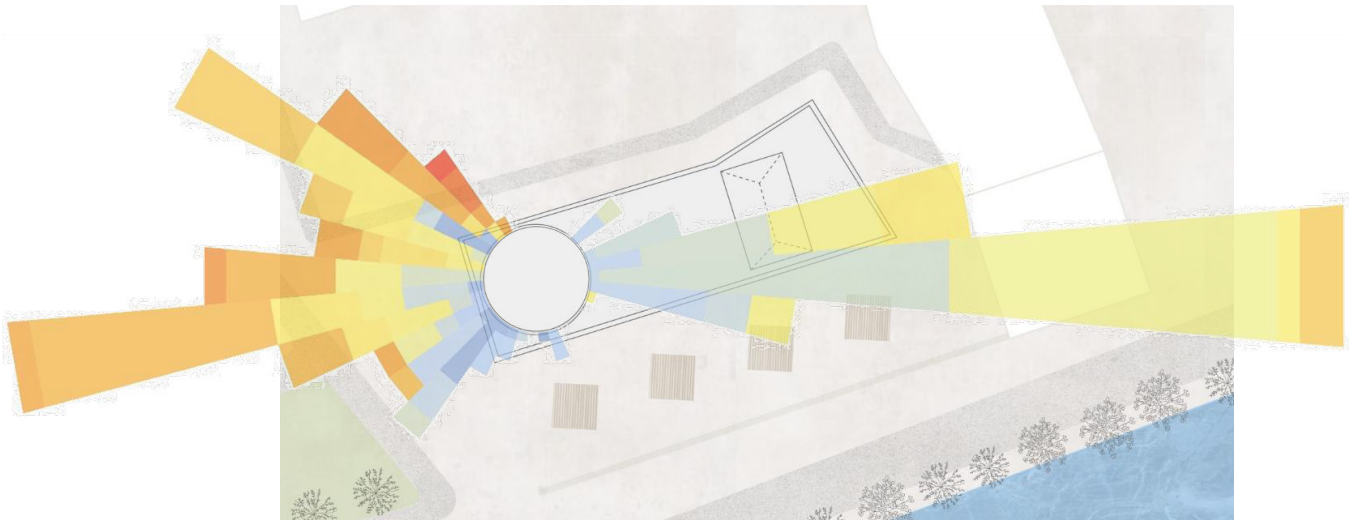

Climate analysis: wind for Dalwigk Tower

The individual façade elements were designed based on a climate analysis. Larger overhangs provide targeted shading and wind protection - both for their own nest and for neighboring modules. To avoid overheating, which is to be expected on the south-west side in particular, the number of nests decreases in this direction. Instead, the nest density increases in the cooler northern areas in order to create better thermal conditions and protected breeding areas for the swallow species.

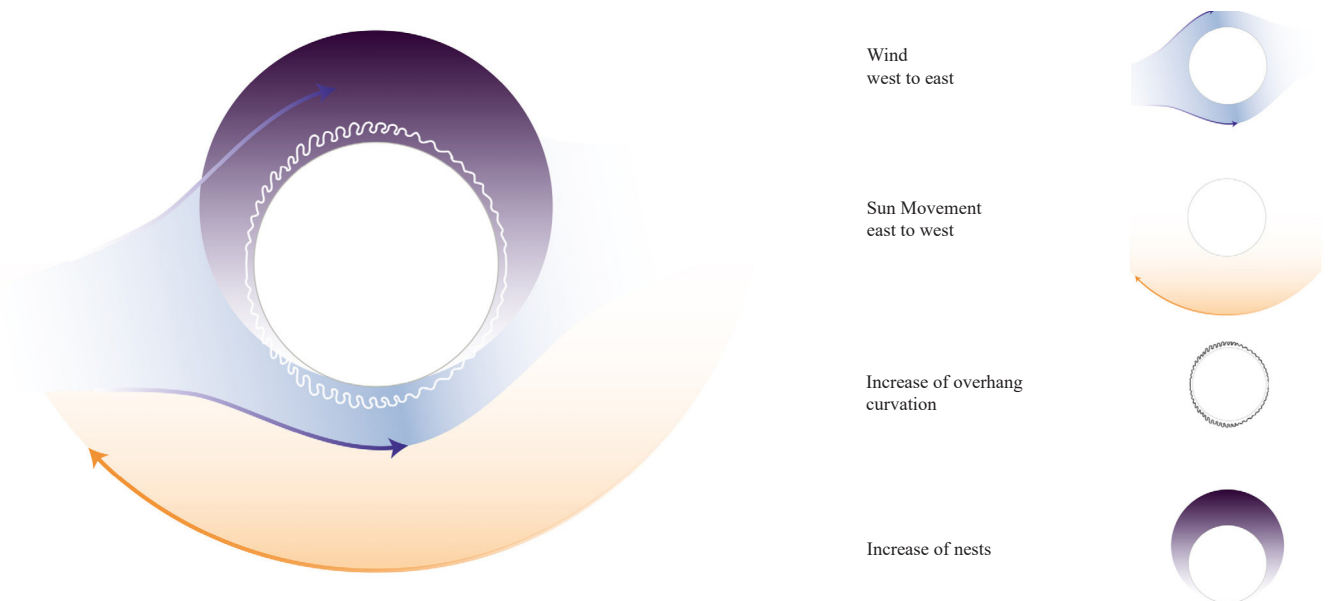

Designdrivers arrangement of the elements on the façade

Swallow-Aided-Design

Where swallows nest, fortune rests.

Final Design



Elevation north-west facade Münzbergstraße 91, Ingolstadt



Element mapping north-west facade Münzbergstraße 91, Ingolstadt

The chosen location is suitable for swallows, as there are numerous sources of food in the surrounding area - including nearby green spaces. The Danube, around 260 meters away, and a local fountain also ensure a supply of water and food. The north-west orientation of the building façade protects against strong solar radiation. The mapping shows that the number of nests decreases from the upper edge of the façade downwards. At the same time, the overhang of the elements decreases towards the bottom, which creates a design and functional progression. Only barn swallow nests were integrated in order to avoid potential disturbance to the residents of the building. The elements close to the ground serve as design fillers without a nest function, as the flight altitude starts at around 4m.

Münzbergstraße 91, Ingolstadt



Visualisation Residential Building Münzbergstraße 91, Ingolstadt

Swallow-Aided-Design

Where swallows nest, fortune rests.

3D Printing Process

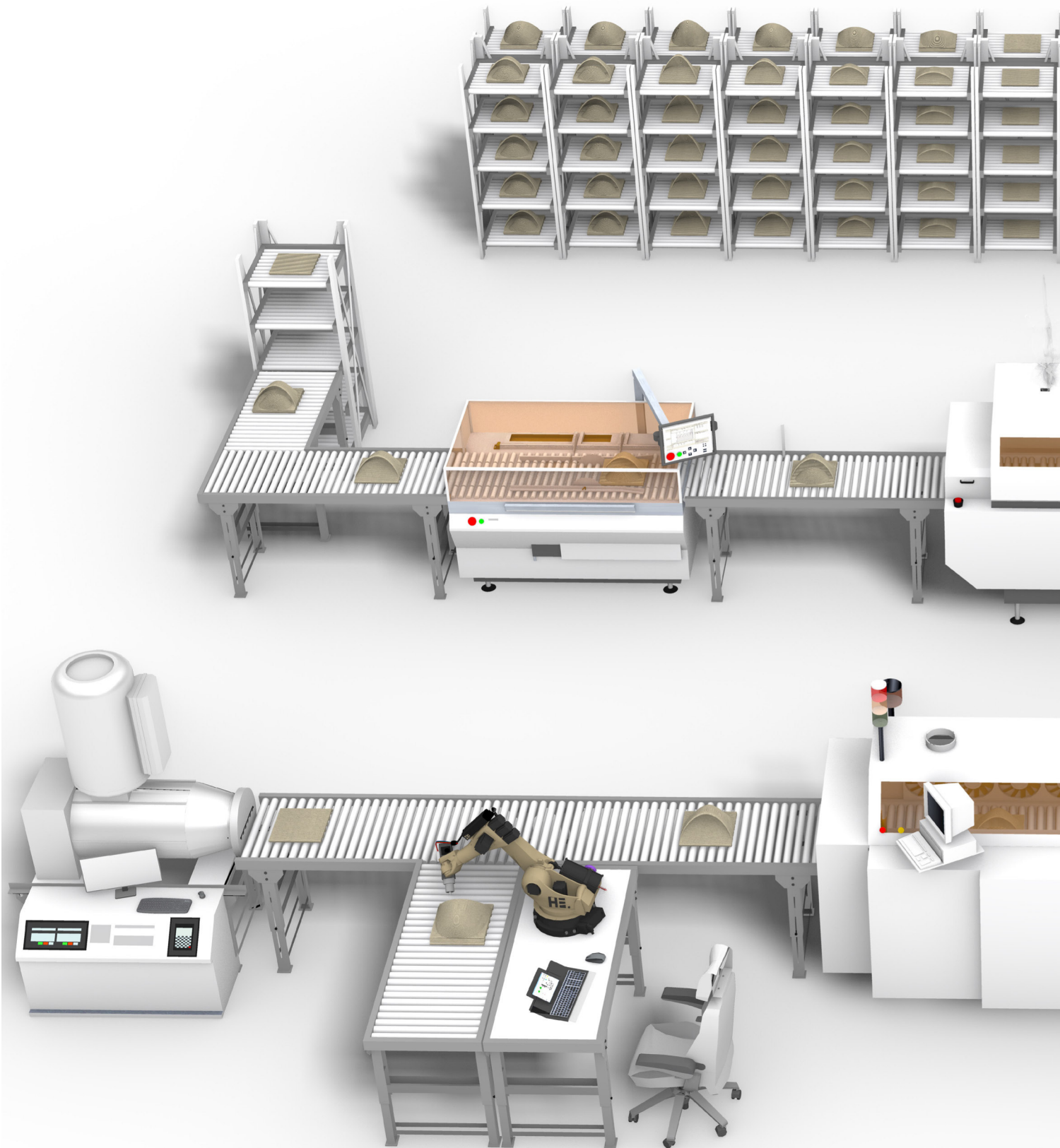

Process of industrial 3D printing of façade elements

Shipping



Firing Process



Drying Process



Swallow-Aided-Design

Where swallows nest, fortune rests.

3D Printing Studies

The known boundary conditions of 3D printing were expanded and refined during prototyping based on practical observations. To achieve stable overhangs and nest shapes, simple parabolas were modeled to enable a stable geometry. The surface of the nests could also be easily adapted: Various sine curve decay patterns were used to create structured textures that were both functional and suitable for printing. It was particularly important to precisely adjust the layer and frame distances in order to obtain clean, even layers of clay. The next development step is to print the shells on a pre-extruded base plate, which will improve stability and manufacturability. In addition, the maximum rotational movement of the robot arm had to be limited to 45° to avoid collisions. The printing speed was adjusted depending on the component: curved, filigree shapes required slower work, while flat elements allowed for up to 100% printing speed.

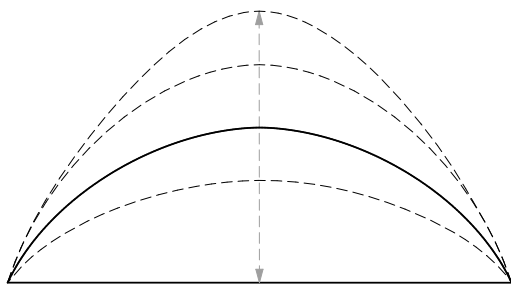

simple parabolas

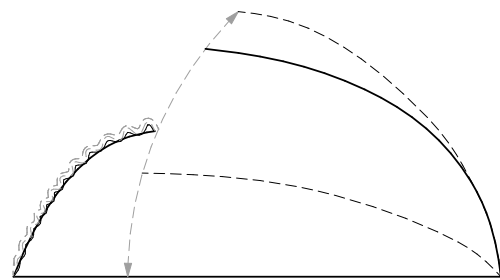

various sine curves

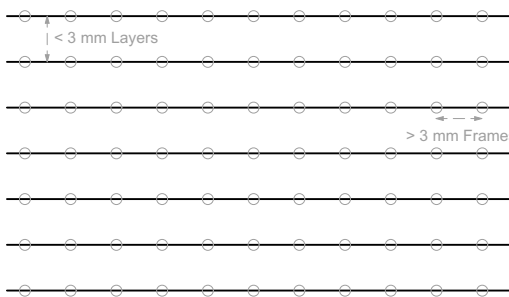

distances



baseplate

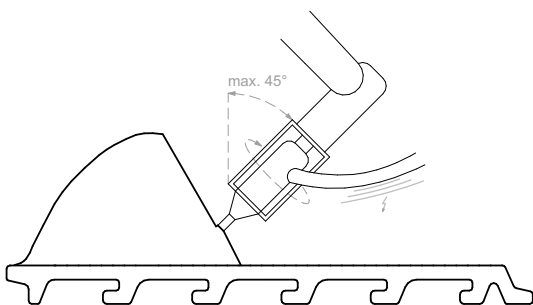

rotation

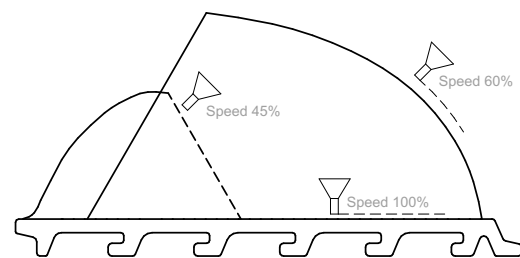

speed

Lessons learned from Prototyping

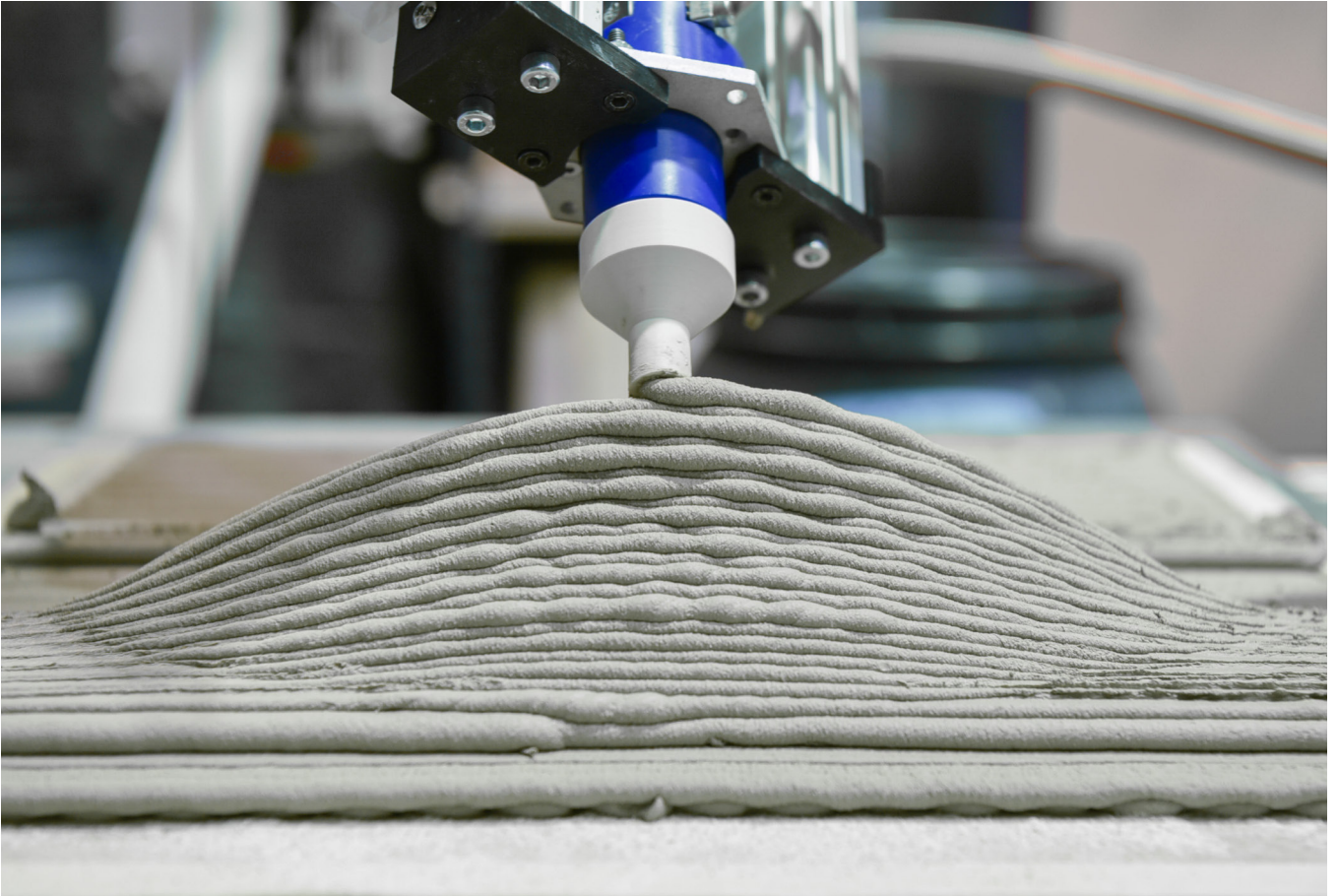

Nestcurving- and Surface-Tests - 1:1 Prototype



Overhangcurving-Tests - 1:1 Prototype

Swallow-Aided-Design

Where swallows nest, fortune rests.

3D Printing Studies

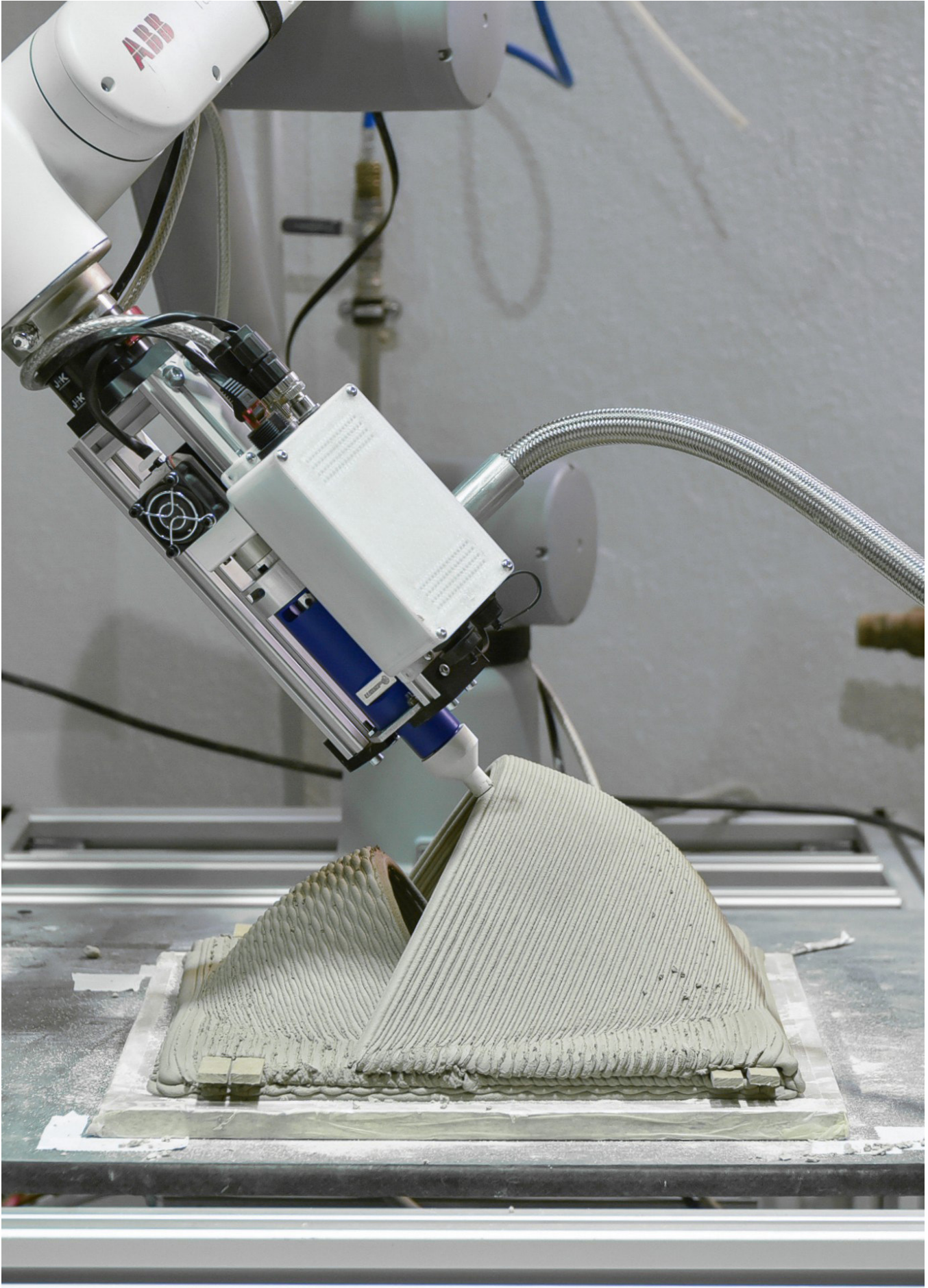

Printing Process Overhang - 1:1 Prototype

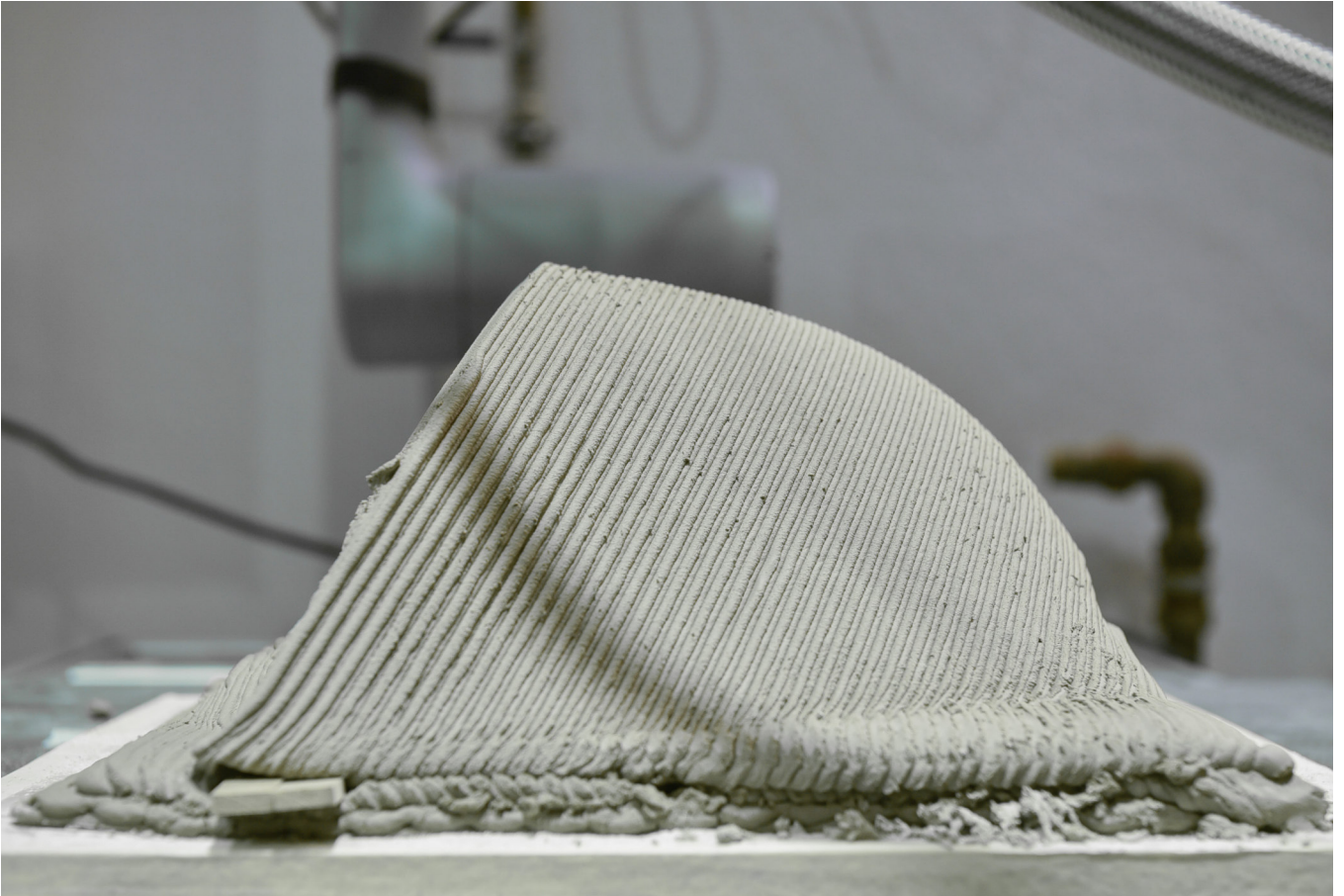

Final Barn Swallows Element Laying - 1:1 Prototype

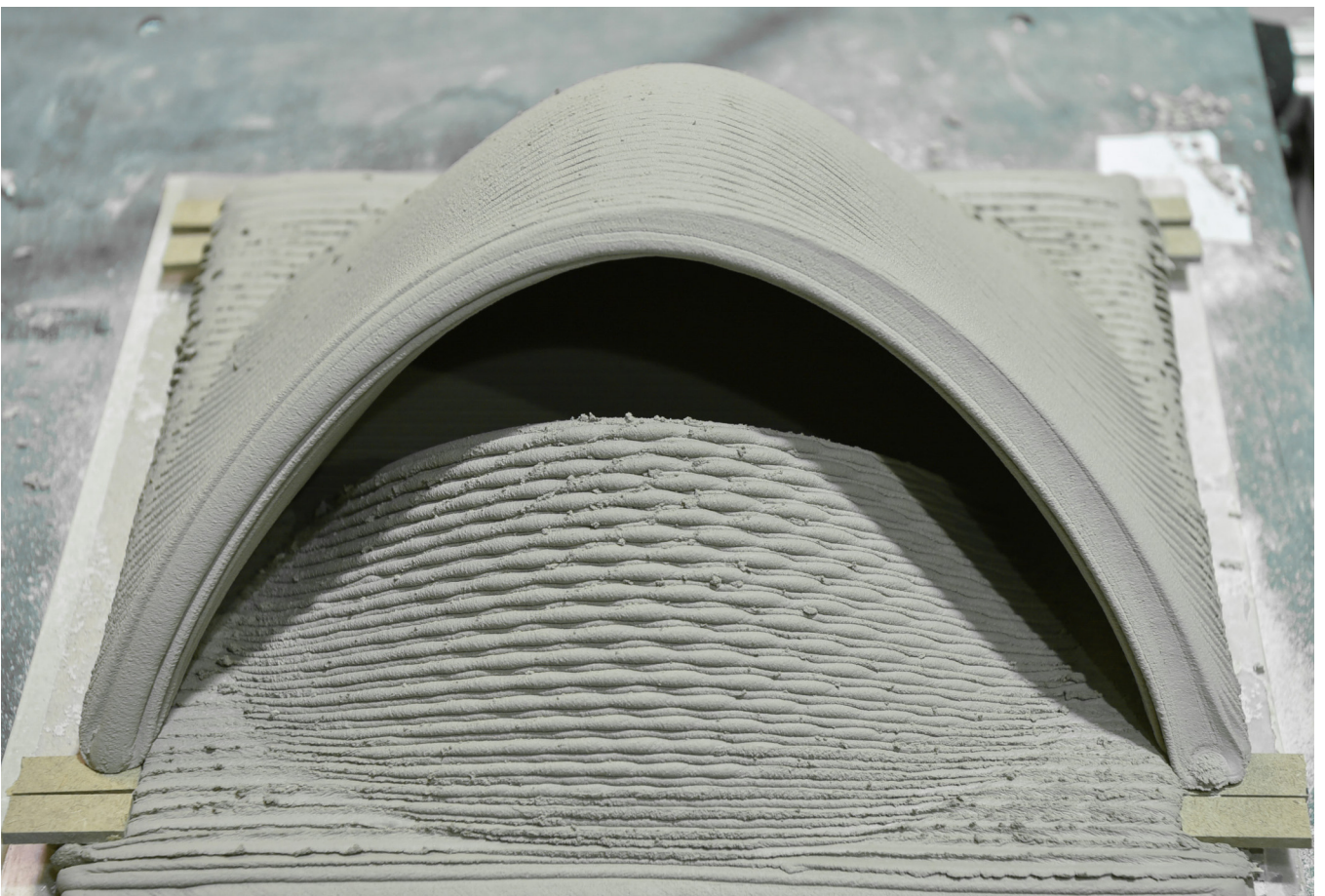

Final Barn Swallows Element Nestopening - 1:1 Prototype

Swallow-Aided-Design

Where swallows nest, fortune rests.

Fabricated Element
1:1 Scale



Underside of the overhang - 1:1 Prototype



Elevation of two barn swallow nest elements - 1:1 Prototype

Fabricated Element
1:1 Scale



Nest opening and surface texture for grip - 1:1 Prototype

Project Title: Dein heimlicher Mitbewohner

Group Members: Lisa Clausen-Schaumann, Marie Valerie Krudl, Cederik Mulkers

Project Description: In line with the principles of Animal-Aided Design, special facade tiles were developed to meet the needs of bats at the Dalwigk Tower. These tiles are adaptable to 60ths buildings in Ingolstadt which are soon undergoing renovation exemplary shown with a design for the Highrise Building at Brückenkopf 8, Ingolstadt.



Dalwigk Tower with Bat-Tiles and Bats at Dusk 1:50

Species Portrait

Pipistrellus pipistrellus
Zwergfledermaus

„is tiny and likes to squeeze in openings of 2-4 cm“

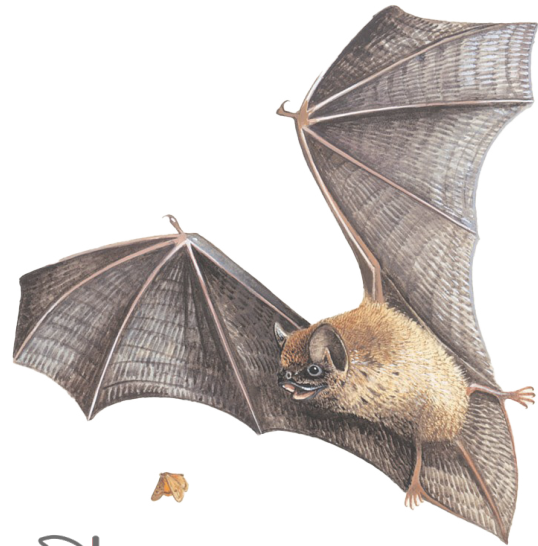

3.5 - 5 cm / ca. 8 g



high noise sensibility



weather protection



hunts small insects

Nyctalus noctula
Grosser Abendsegler

„likes to spend spring and fall in facades in Ingolstadt“



8.2 cm / ca. 28 g



high noise sensibility



weather protection



short distance to hunting grounds

Dein heimlicher Mitbewohner

Design Concept

Threats for the Bats - Building Renovation

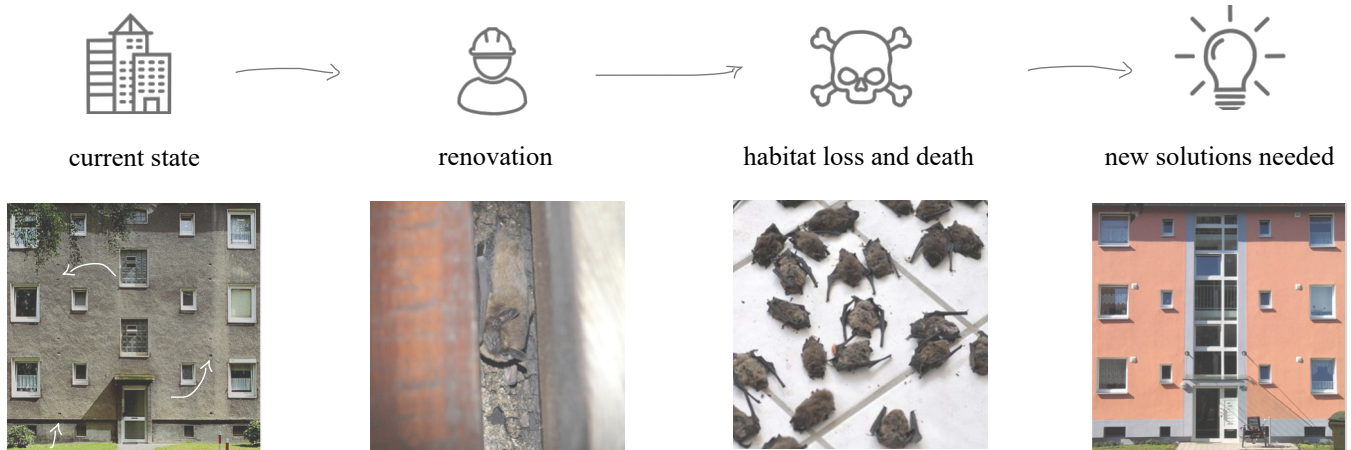

The 60ths Buildings in Ingolstadt

- 60ths buildings
- greenery / feeding ground
- river / feeding ground
- noise

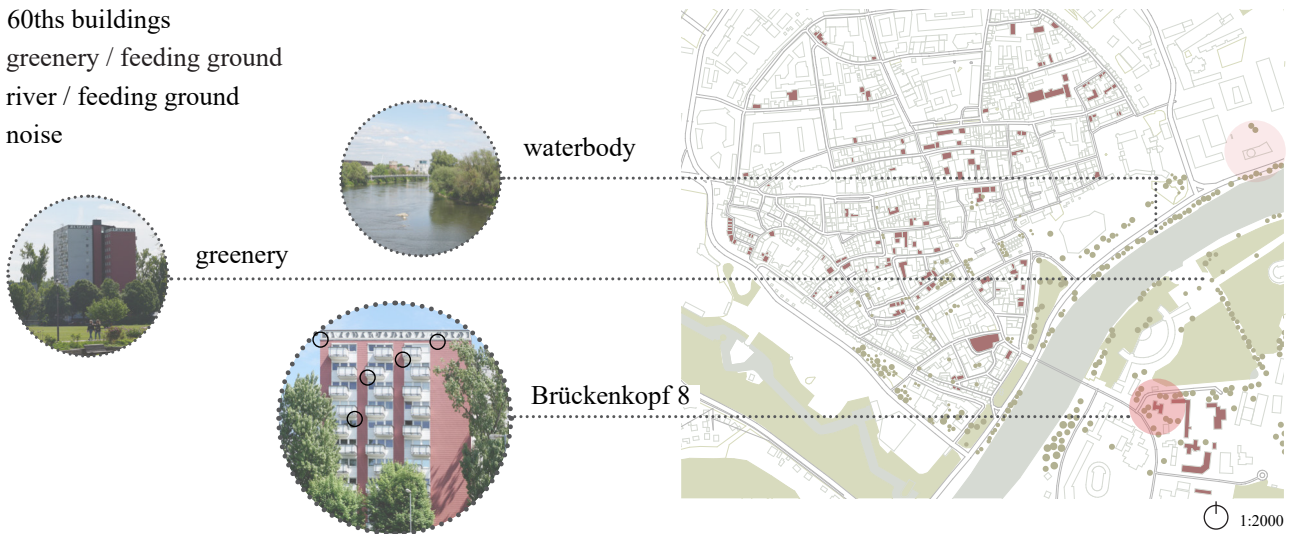

The Dalwigk Tower

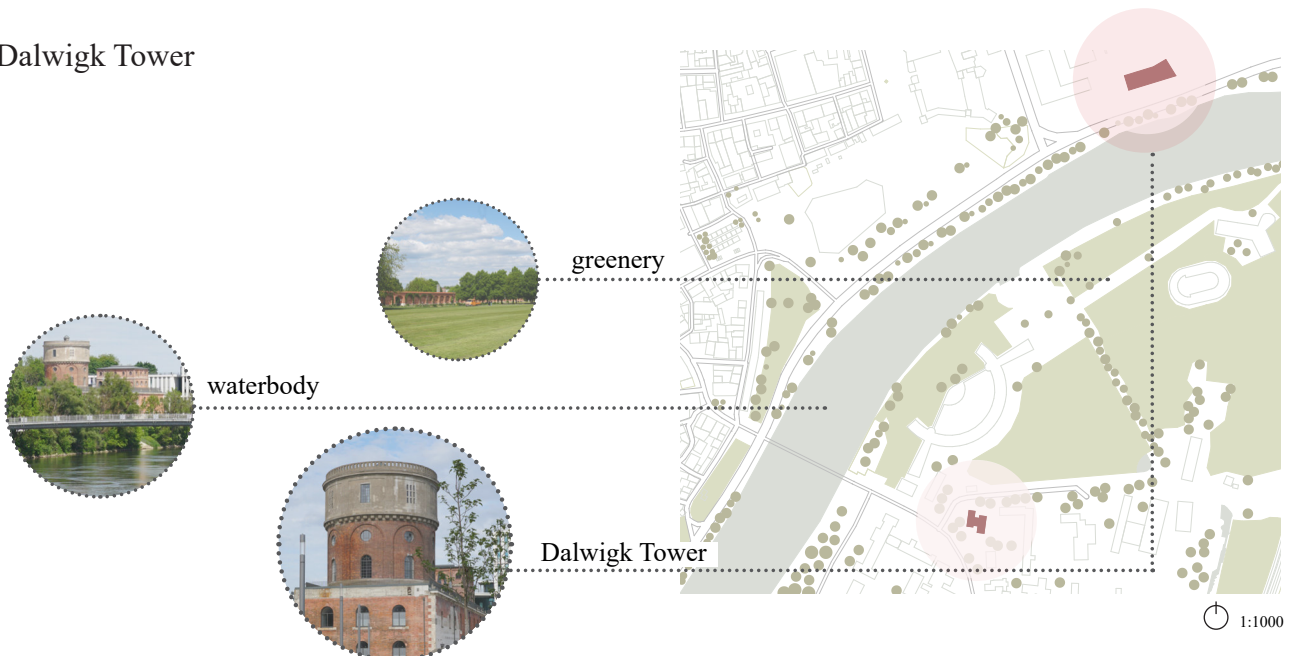

Parametric Design

Parameters - Species, Noise, Climate, Facade System
M 1:20



species and noise

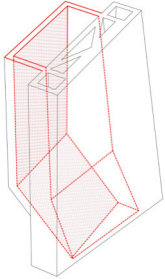

noise, temperature, solar radiation

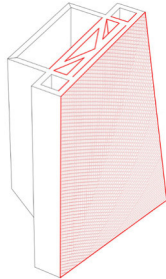

noise, temperature, solar radiation

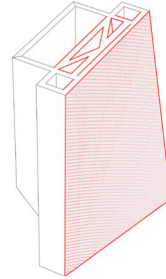

facade system

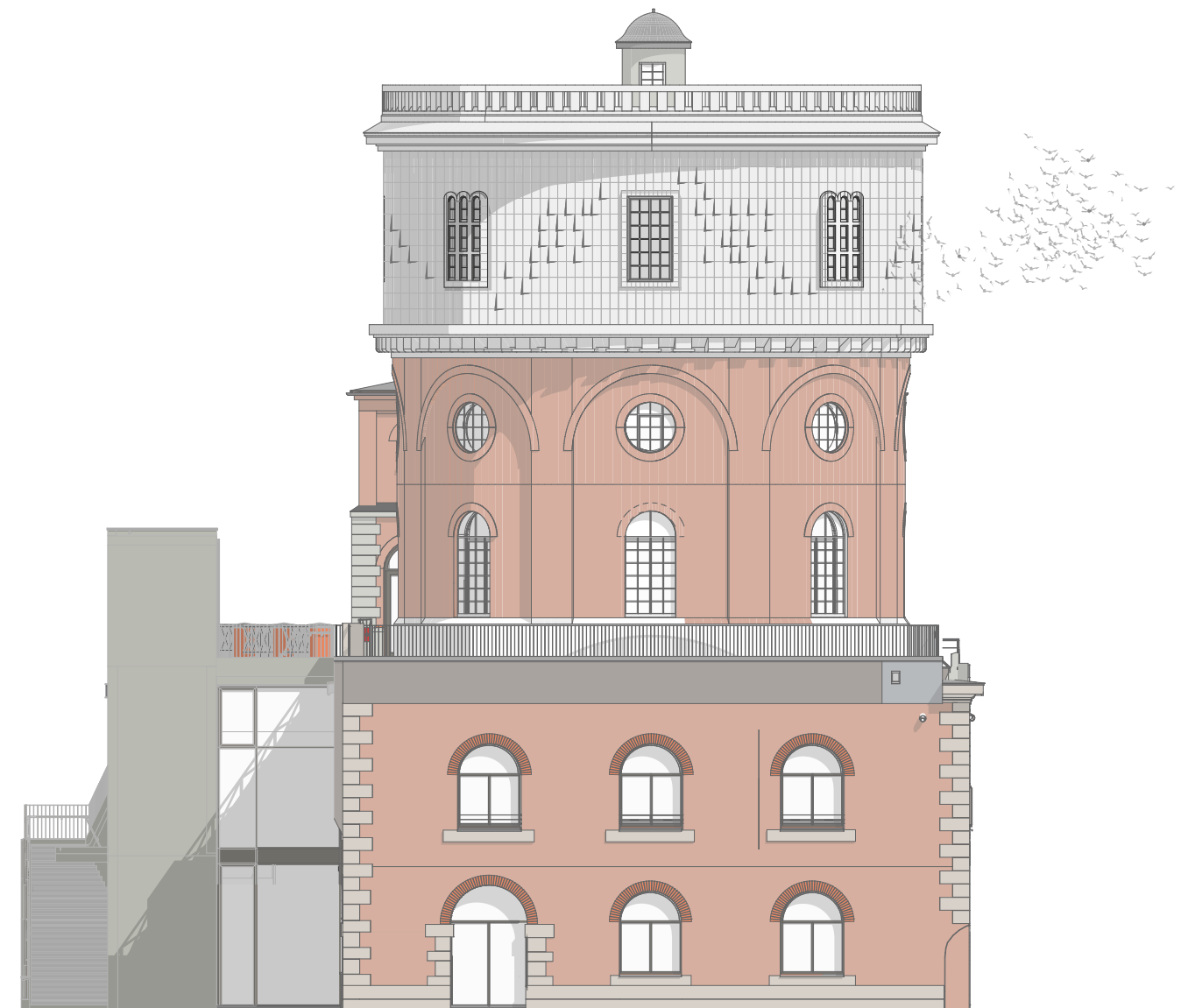
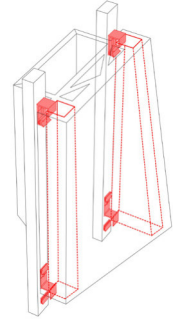

Elevation of the Dalwigk Tower 1:150

Element - Initial Idea

a normal tile

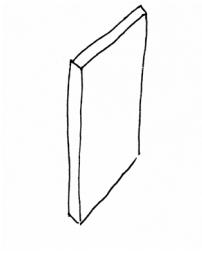

small hint

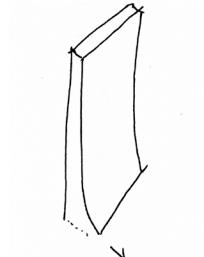

invitation to bats

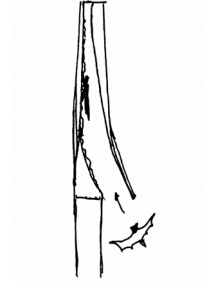

small hint

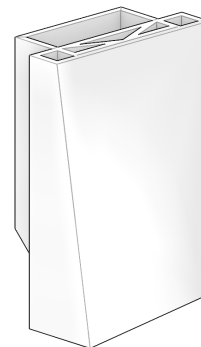

the bat tile

Element - Parameter



species



noise



climate



facade system

Element Parameters and Initial Idea

Element - Parameters - Summary

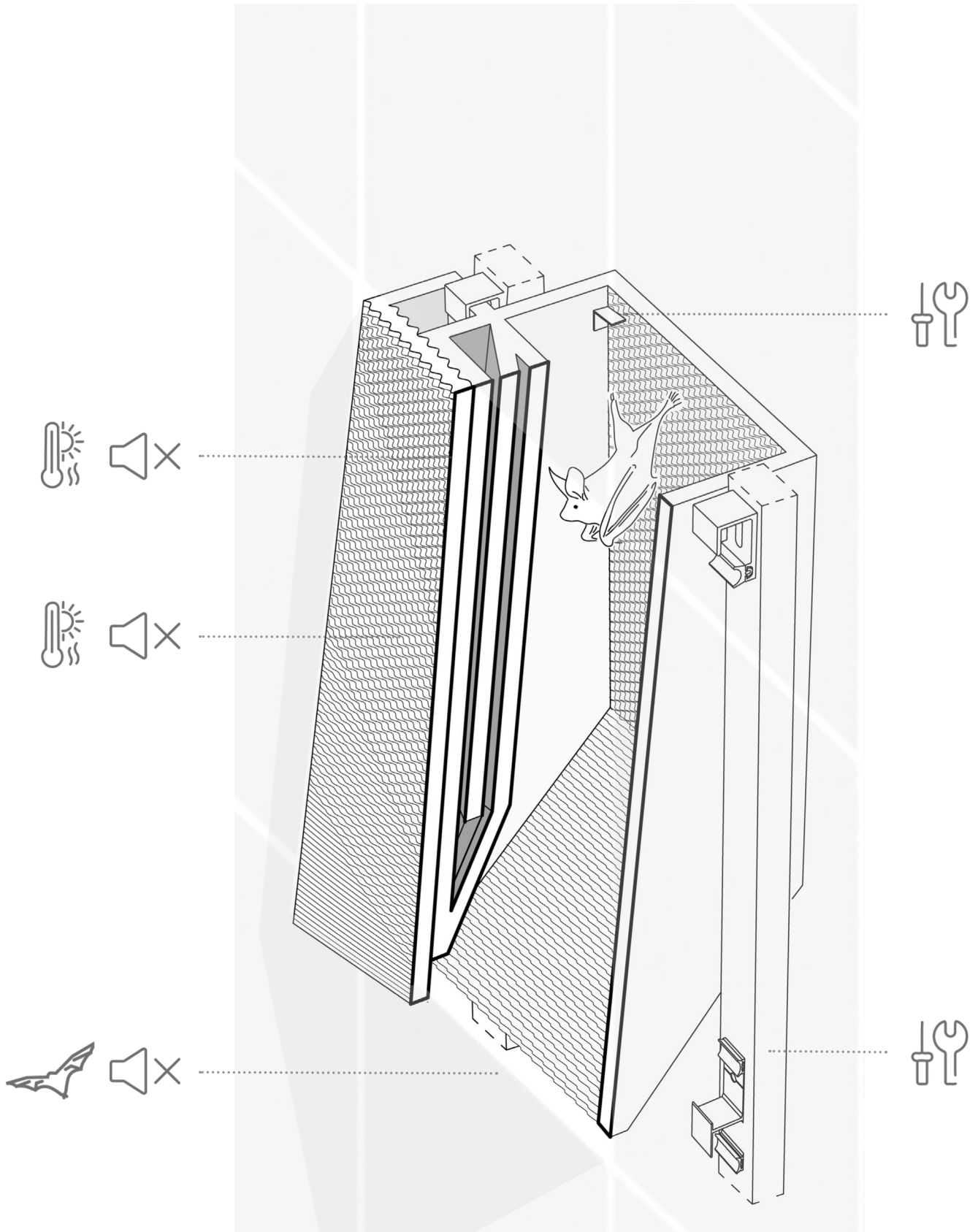

Axonometry with the Inner Space for the Bats 1:5



Visualisation of the Dalwigk Tower at Dusk 1:150

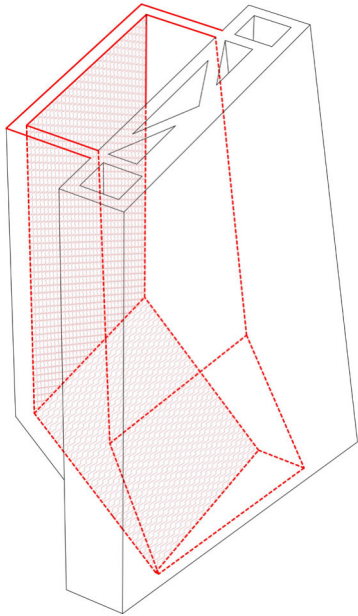

Nesting Box - Microstructure

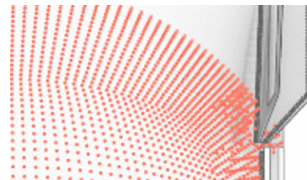

Since bats are highly sensitive to sound and rely on their claws to climb within the interior of the roosting element, a microstructured surface was specifically developed. This structure not only supports physical grip but also enhances acoustic orientation, contributing to the effectiveness of the bats' echolocation system. The entrance shape was carefully designed to minimize the sound path into the cavity, reducing disturbance.

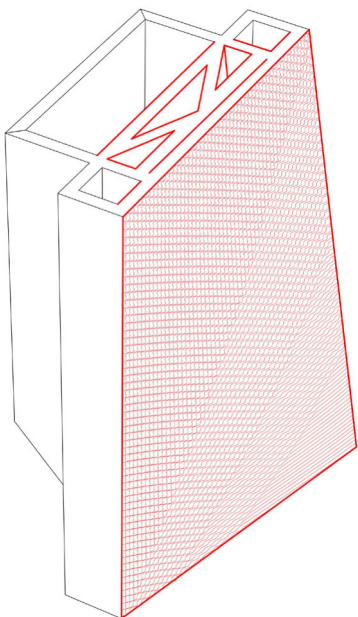

Noise Analysis - Microstructure

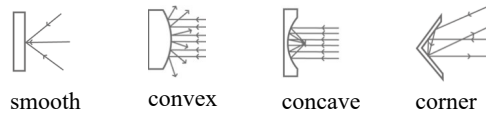

The microstructure, also applied to the exterior surface of the element, further contributes to noise reduction in urban settings. As shown in the diagrams, the zigzag-shaped surface pattern is particularly effective in dispersing sound waves. This diffusion helps to break up disruptive noise reflections, minimizing acoustic disturbances around the roosting areas. For the bats, this means easier orientation and a calmer environment.

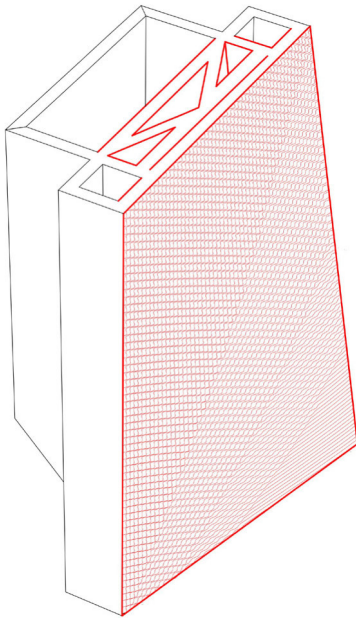

Insulating Layer - Microstructure

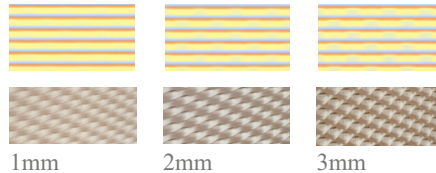

This microstructure also serves as a tool for trying to reduce the urban heat island effect. It is based on findings from a physical study of the Tesla Block, which demonstrated that microstructured surfaces can reduce surface temperatures. The textured geometry increases surface area and promotes heat dissipation. The mass of clay in the insulation layer, along with the air gaps, reduce noise transmission and enhances temperature control through phase shift.

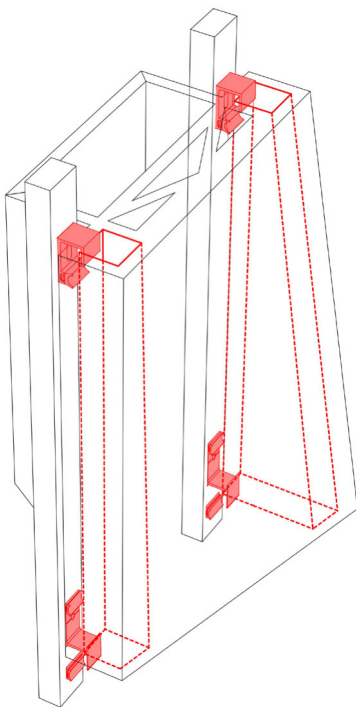

Facade System

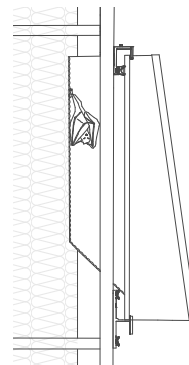

The facade elements are mounted using the “SQR” Tonality clipping system with vertical rail profiles. This construction allows each tile to be lifted vertically and removed with ease, enabling straightforward cleaning, inspection, or replacement without affecting adjacent components. The modularity of the system ensures long-term durability while allowing for adaptation to changing technical, ecological, or maintenance requirements.

Dalwigk Tower, Ingolstadt



Visualisation of the Dalwigk Tower at Dusk 1:50



Elevation North Facade Brückenkopf 8, 85051 Ingolstadt

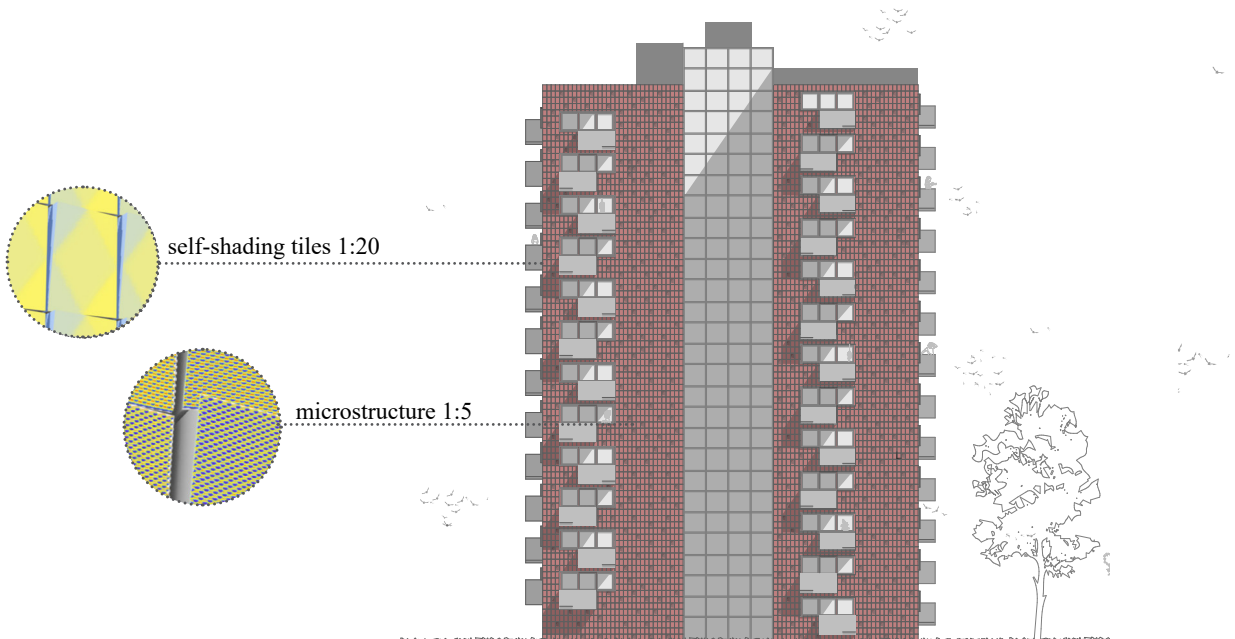

Elevation South Facade Brückenkopf 8, 85051 Ingolstadt

The high-rise building at Brückenkopf 8 in Ingolstadt was identified as a suitable case study within a survey of 1960s buildings scheduled for renovation. In line with the principles of Animal-Aided Design, special facade tiles were developed to meet the needs of bats. The system can be integrated into common facade constructions as a ventilated curtain wall system. Bat habitats are grouped in three stages alongside standard tiles and placed with a distance from windows to respect both animal and human needs. On the south-facing facade, rotated tiles create a strong self-shading effect. Microstructures on the surface further support noise reduction and might help mitigate the urban heat island effect—findings supported by physical testing on the Tesla Block.

Elevation of the Highrise Building at Brückenkopf 8, Ingolstadt 1:500

Brückenkopf 8, Ingolstadt



Visualisation of the Highrise Building at Brückenkopf 8, Ingolstadt 1:25

Dein heimlicher Mitbewohner 3D Printing Studies 1:1 Scale

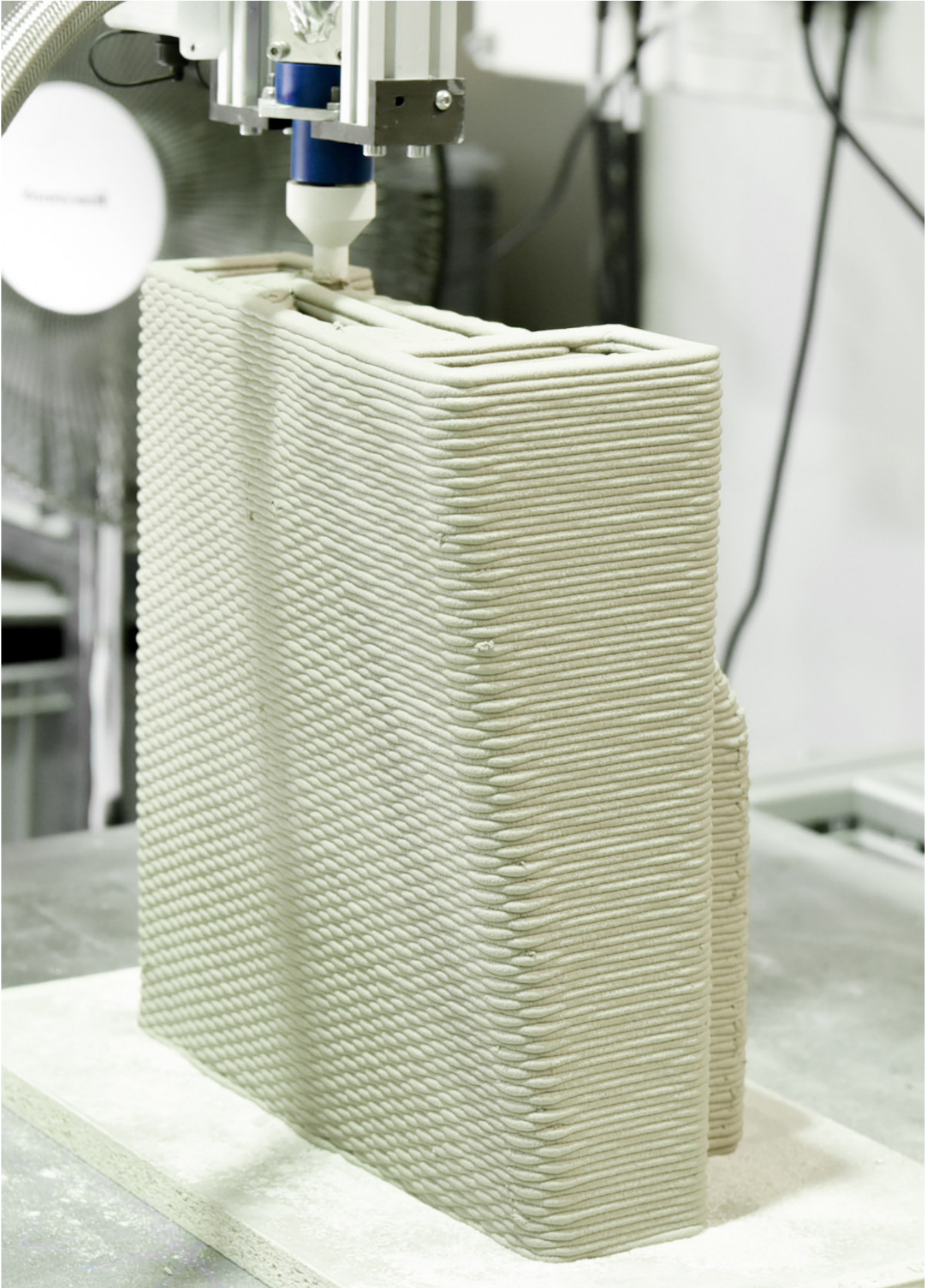

Finalized Bat-Tile printed Upside-Down 1:1

3D Printing - Parameters



design idea



microstructure



overhang



outlook



Design Idea - Printing Path

To counteract deformation resulting from the nozzle's tendency to drag on the underlying layers, we developed a printing path that alternates between clockwise and counterclockwise rotation.

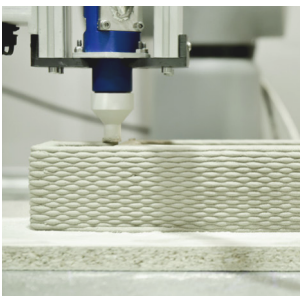

Microstructure - Increasing the Amplitude

One of the initial challenges we encountered was the visibility of the exterior texture. The pattern on the printed tile appeared less pronounced than in the 1:1 samples generated from our digital model.

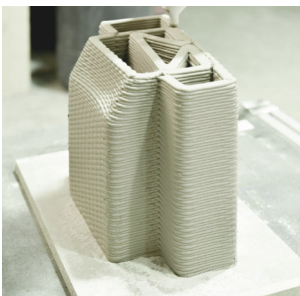

Overhang - Minimizing Sharp Angles

A second challenge relates to deformation, visible in areas such as the slightly warped triangular feature on the front façade and, more critically, in the sloped bat box at the rear, where angle, height, and thermal stress led to noticeable inaccuracies and loss of definition.

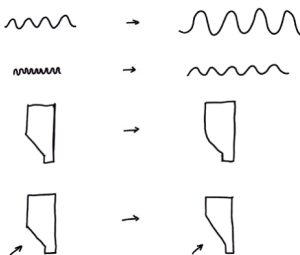

Outlook - Solutions

As shown in the sketch, increasing the wave amplitude improved the legibility of the outer surface. Deformation will be further mitigated by reducing sharp angles and introducing smoother, curved transitions.



Mockup with the Fired Bat-Tile and one Regular-Tile in the Tonality Substructure 1:1

**Fired Elements
1:1 Scale**



Removable Bat-Tile with Regular-Tile 1:1



Backside of the Batbox of the Bat-Tile in the 1:1 Mockup

Fired Elements
1:1 Scale



Entrance for the Bats at the Bat-Tile and Close-Up of the Microstructure 1:1

CAVE

Introduction

Project title: CAVE

Group members: Yuejiao Xie, Sofia Alt Motta, Yaxi Wang

We set out to create an inviting space for birds to nest, one that feels familiar, protective, and rooted in their natural behaviour. Our design draws from the habitats of the Black Redstart and the Jackdaw, two species known to nest in the small crevices and ledges of rocky cliff-sides.

This approach is expressed through a dual-layered system. The outer shell responds to the surrounding climate with angled surfaces provide shading and cooling, and protrusions form overhangs shielding the structure from rain and direct sunlight.

The inner shell forms the actual nesting space. Inspired by natural cavities, its shape and openings are carefully tuned to the species-specific preferences of cavity-nesting for Jackdaws and ledge-nesting for Black Redstarts.

To realize this design, we developed a 3D-printed structural form composed of continuous folded surfaces. This method allows the inner and outer conditions to be formed in one integrated gesture, merging structural performance, spatial definition, and environmental responsiveness into a single architectural expression.



South-West View of the Tower

The Jackdaw (*Corvus monedula*)



Size

Length: 34.0 – 39.0 cm

Wingspan: 64.0 – 73.0 cm

Breeding Season

April to July

Typically one brood per season

Migration Patterns

Jackdaws are partially migratory. While some individuals migrate seasonally, a significant portion of the population remains in Germany year-round.

Nesting Behaviour

Jackdaws are colonial nesters that form strong, monogamous pair bonds. On average, colonies consist of around 9 to 10 breeding pairs, with nests spaced approximately 2 to 10 meters apart.

Cavity Nester:

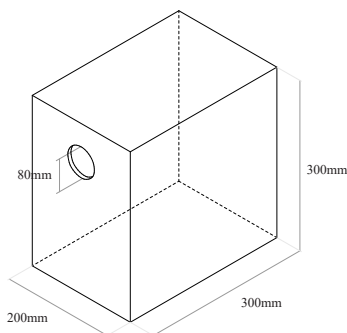

The Black Redstart (*Phoenicurus ochruros*)

Size

Length: 13.0 – 14.5 cm

Wingspan: 23.0 – 26.0 cm

Breeding Season

Mid-April to mid-July

Typically two to three broods per season

Migration Patterns

Black Redstarts are partially migratory. However, recent trends show an increase in overwintering individuals, particularly in urban areas of Germany.

Nesting Behaviour

Black Redstarts are strongly territorial, especially during the breeding season. Unlike colonial nesters, they prefer to nest well apart from one another, typically maintaining distances of over 10 meters between nests.



Half-Cavity/Ledge Nester:

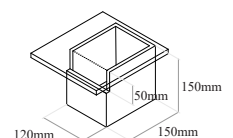

CAVE

Concept and Goals

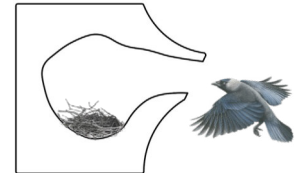
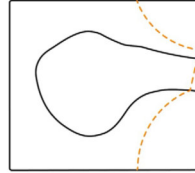
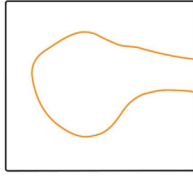

Our goal was to create a shelter that supports bird life year-round, offering protection during the breeding season and serving as a roosting spot in winter. Inspired by the natural behaviour of the Black Redstart and Jackdaw, which nest in cliff-side cavities, we focused on forming a cave-like space that feels secure and weather-resistant. By angling the sides and front, the structure effectively shields against wind and rain. This approach led to a distinctive fin-shaped form, combining environmental performance with a protected, species-appro-



Sketch - Jackdaw in Natural Habitat

Jackdaw Nest

The Jackdaw nest tile measures 400mm in height and length, with a nesting depth of 300mm. The entrance, 80mm wide and positioned in the upper half, reflects the species' preference for cavity nesting.

The inner cavity features an organically shaped cavity that mimics the natural rock crevices these birds inhabit, providing a secure and familiar nesting environment.

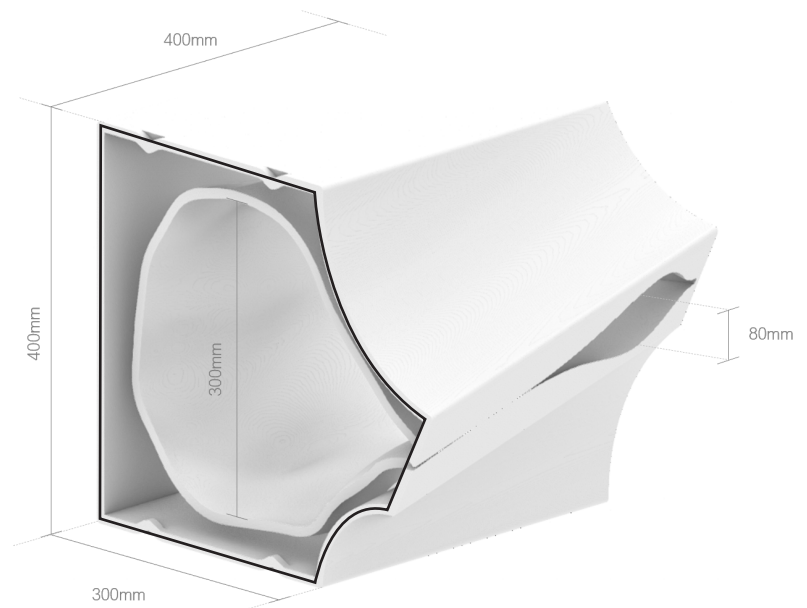

Isometric Jackdaw Nest Tile

Black Redstart Nest

The Black Redstart nest tile measures 400mm in height and length, with a nesting depth of 200mm. Its 50mm-wide entrance is positioned in the middle and features a pronounced overhang to suit the species' preference for ledge nesting.

The inner cavity is smaller and shallower than the Jackdaw's, designed to reflect the Black Redstart's tendency for half-cavity nests, offering a more open yet sheltered space.

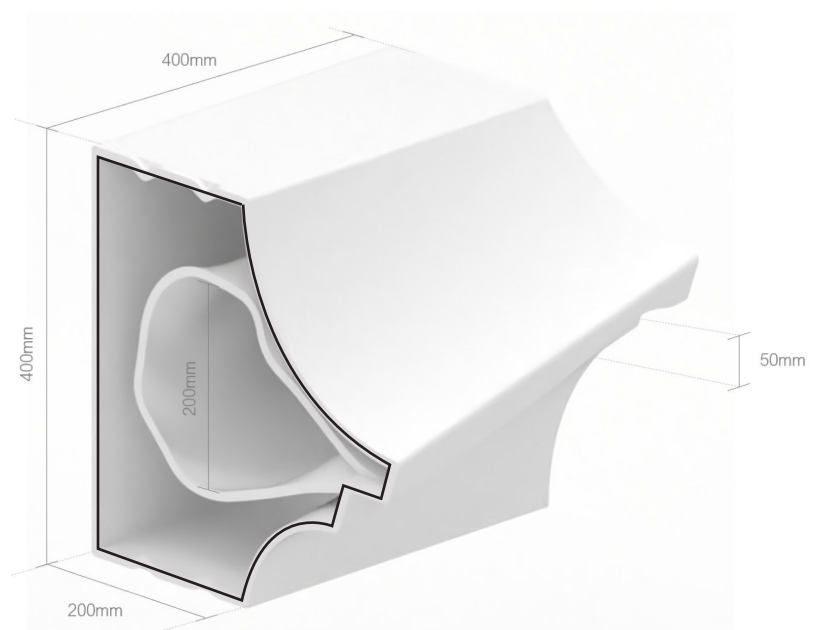

Isometric Black Redstart Nest Tile

The facade installation system plays a crucial role in balancing functionality, aesthetics, and ease of maintenance. The Tonnality® U-VK system offers seamless integration of bird nesting tiles while ensuring durability and adaptability.

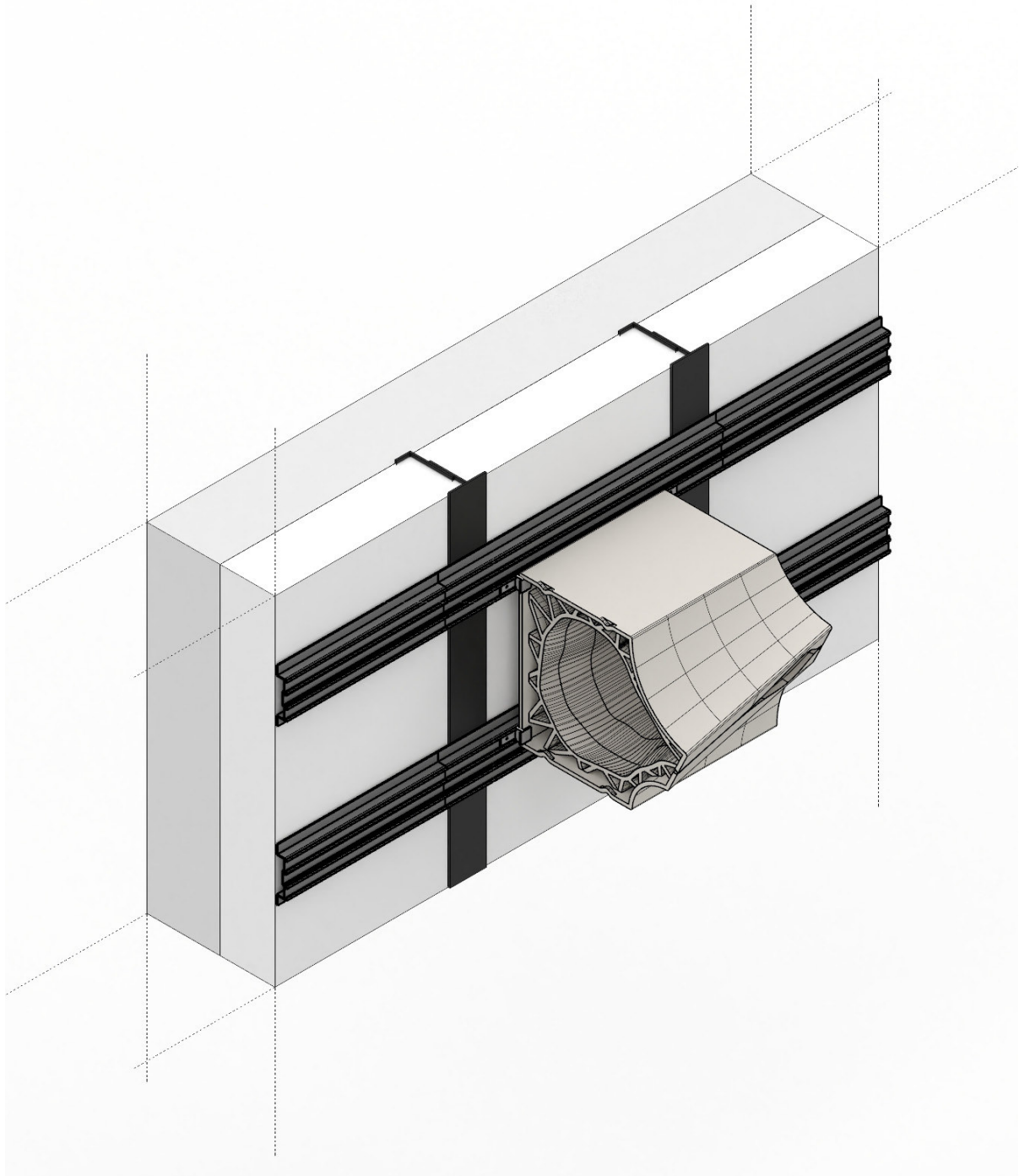

Isometric Drawing of Facade Installation using Tonnality® U-VK system

Facade Installation

Table Projection Facade Installation System for the Jackdaw Tile

Section 1:20

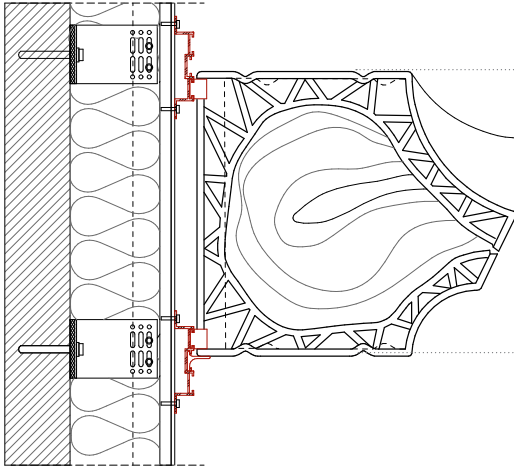

Elevation 1:20

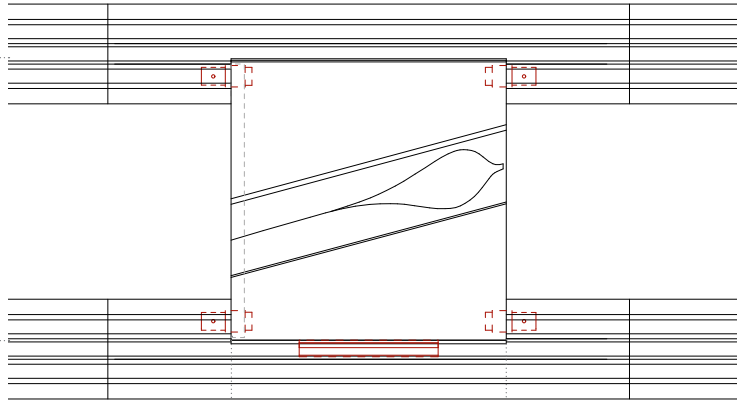

Plan 1:20

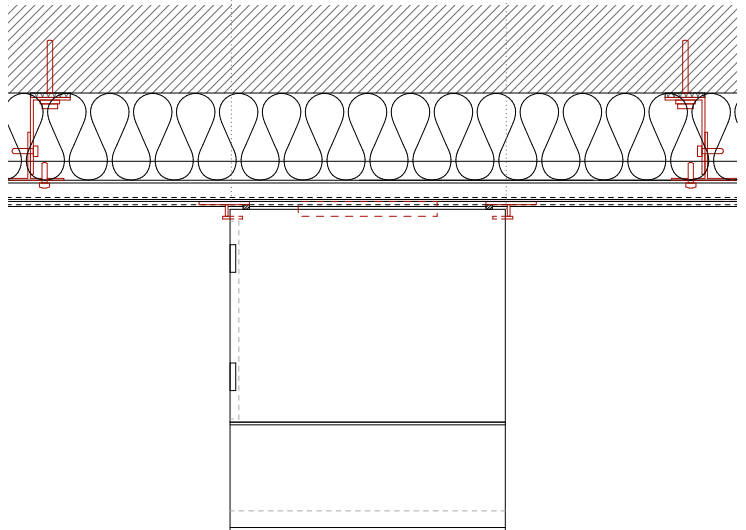

The facade installation utilizes the Tonnality® U-VK system, featuring vertically mounted MP components secured by four hooks at each corner and an additional fastening at the bottom to attach the tile firmly to the facade. This system avoids any visible fixtures, ensuring a clean aesthetic and is universally adaptable to various tile widths. Furthermore, it allows for easy tile replacement, essential for nest-box maintenance. As a stocked system, replacement parts like hooks and rails are readily available, simplifying repairs and upkeep.

The Maintenance was accounted for during the design of the nest tile.

Two small grooves on the top side and two on the bottom simultaneously act as the lock and release for the maintenance lid, which protects the enclosure.

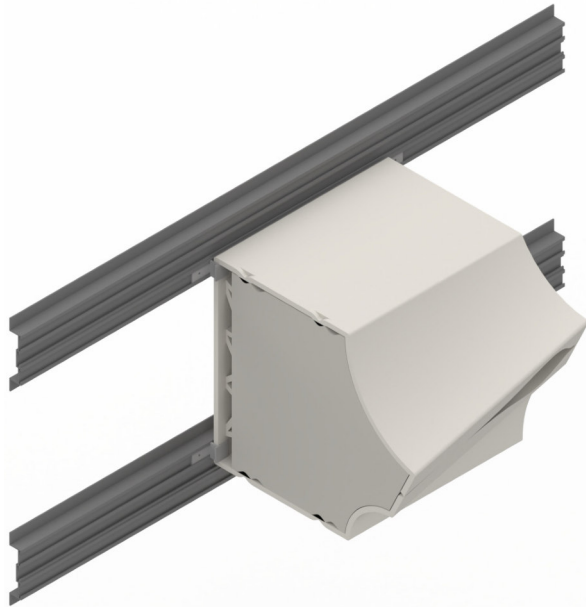

Step 1: In this position, the lid closes off the nesting space while allowing for rear ventilation.

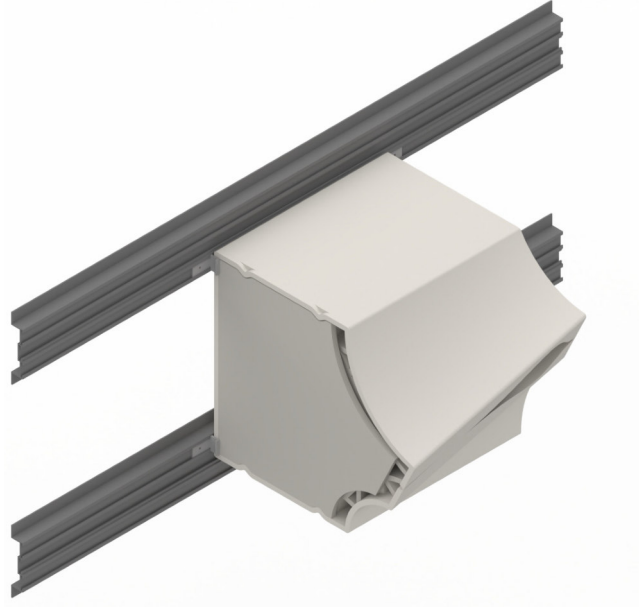

By sliding the lid back, the corresponding grooves align, allowing the cap to be removed.

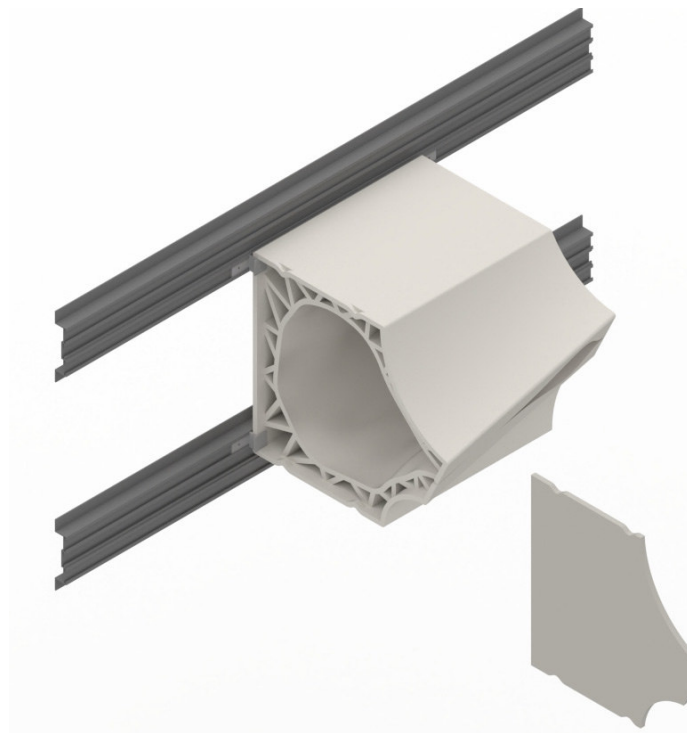
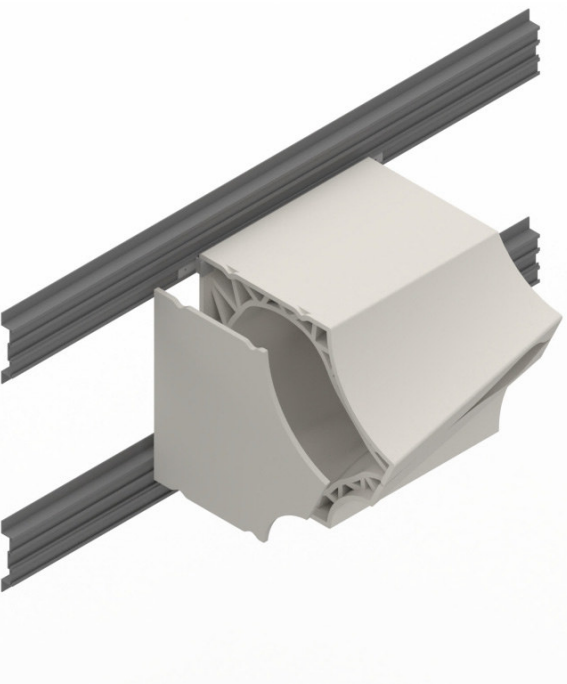

Step 3 and 4: Completely remove the cap to access the nest interior. Cleaning of nests are recommended at least once a year, outside of breeding season. Using cloths, remove old nest material, and clean the nest box to avoid proliferation of parasites and bacteria. The presence of old nests may also discourage new nesting.

3D Printing Process

The fabrication of the tile played a central role in the development of the project, with a strong focus on material experimentation and digital fabrication. The tiles were produced using ceramic 3D printing, a method that allowed us to achieve the complex geometry required to accommodate both functional and ecological needs.



Pictures of the Printing Process

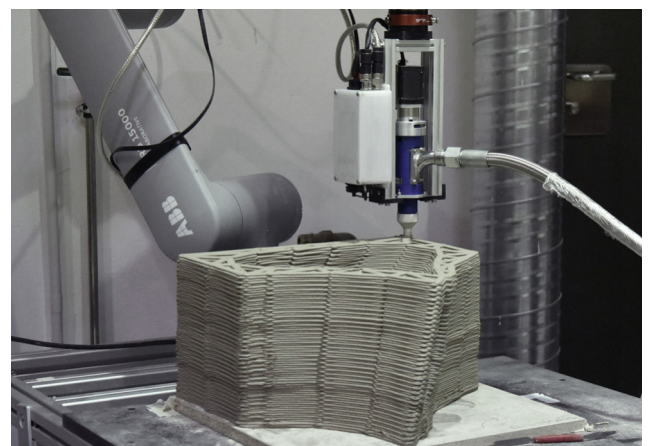
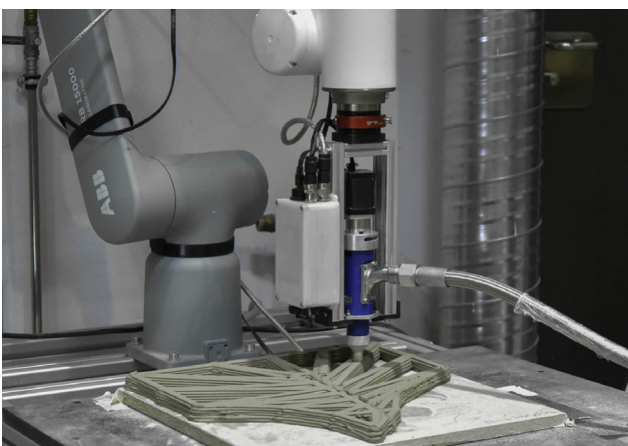

One of the advantages of 3D printing is its ability to produce customized, intricate forms in a single manufacturing process, with minimal waste and high precision.

To achieve the final shape, each tile was printed standing vertically, rotated 90 degrees from its final mounted orientation. This approach helped ensure the correct build-up of the layered structure.

Growing Structure

A key focus of our design was the development of a continuous, integrated structure. With a single printing path, the tile forms its outer shell, inner shell, and internal support system in one go. This allowed for a more seamless and efficient fabrication process. Particular attention was given to the "growing" internal structure, an adaptive geometry that develops organically as it conforms to the irregular contours of the nesting space inside.

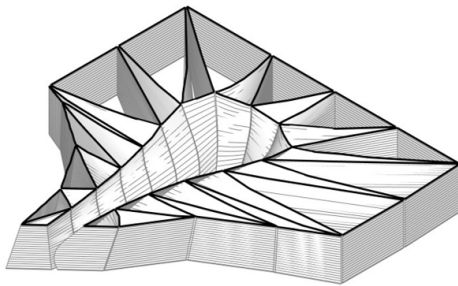

Bottom of Growing Structure

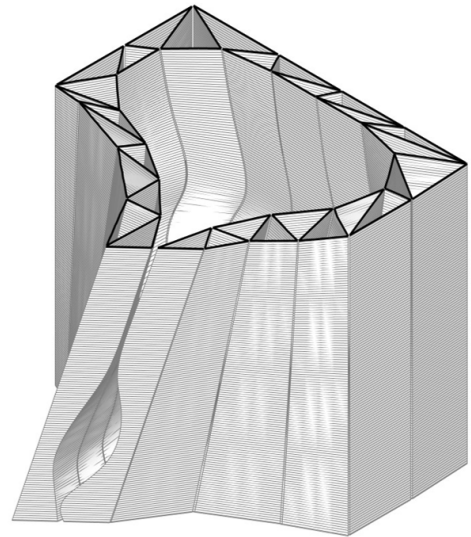

Top of Growing Structure

Alternating Printing Path

To ensure structural stability during the printing process, we implemented a layered path strategy. Each layer alternates in direction, first clockwise, then counter-clockwise. This helps to reduce distortion and prevent dragging or twisting of the lower layers. This adjustment was key in maintaining geometric fidelity and print consistency, especially with the steep angles and overhangs of our design.

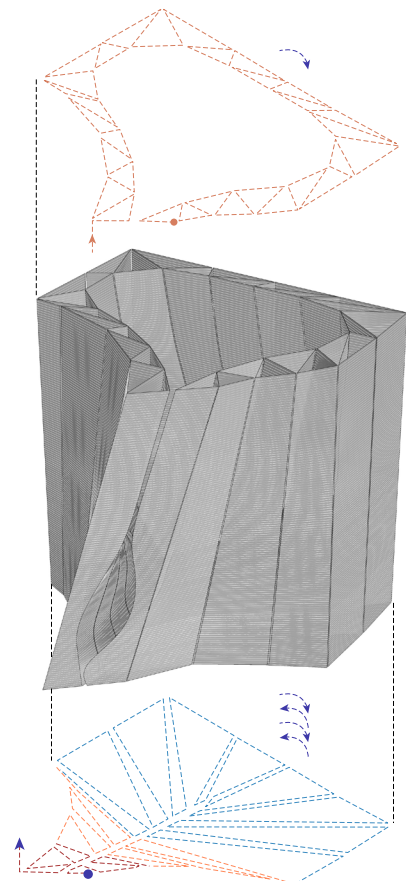
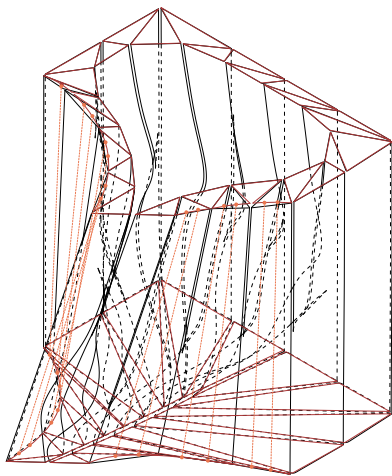

Diagram of Altering Print Path

Form Optimization

The prototyping phase was essential in refining both the form and performance of the tile. One insight was the need to optimize the inner structural grid. Future iterations will use predominantly equilateral or near-equilateral triangles, as these offer better material distribution and structural efficiency while reducing overall weight.

We also recognized the potential for enhancing the outer curvature of the tile. The current prototype is made of several straight-edged segments, which follow the base of the internal triangle structure. By introducing more connecting points, we can create a smoother, more continuous curve while preserving the same printing logic.



Additional Points to Curve Shape

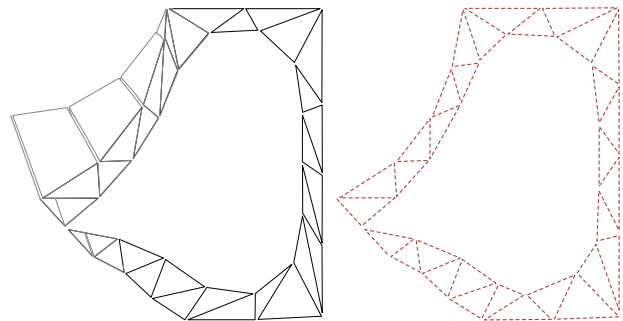

Comparison Between Prototype and Optimization

Dynamic Speed Adjustment

Lastly, speed variation across different areas of the print can aid in increasing print quality. This differential control helps balance print time efficiency and manage the stress and complexity of the geometry as it develops around the inner nesting shell.

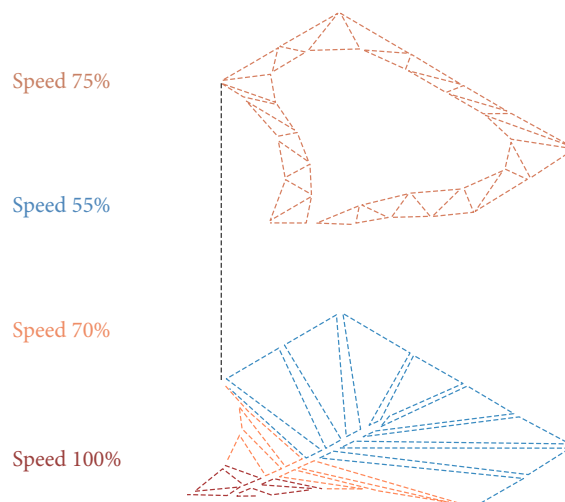
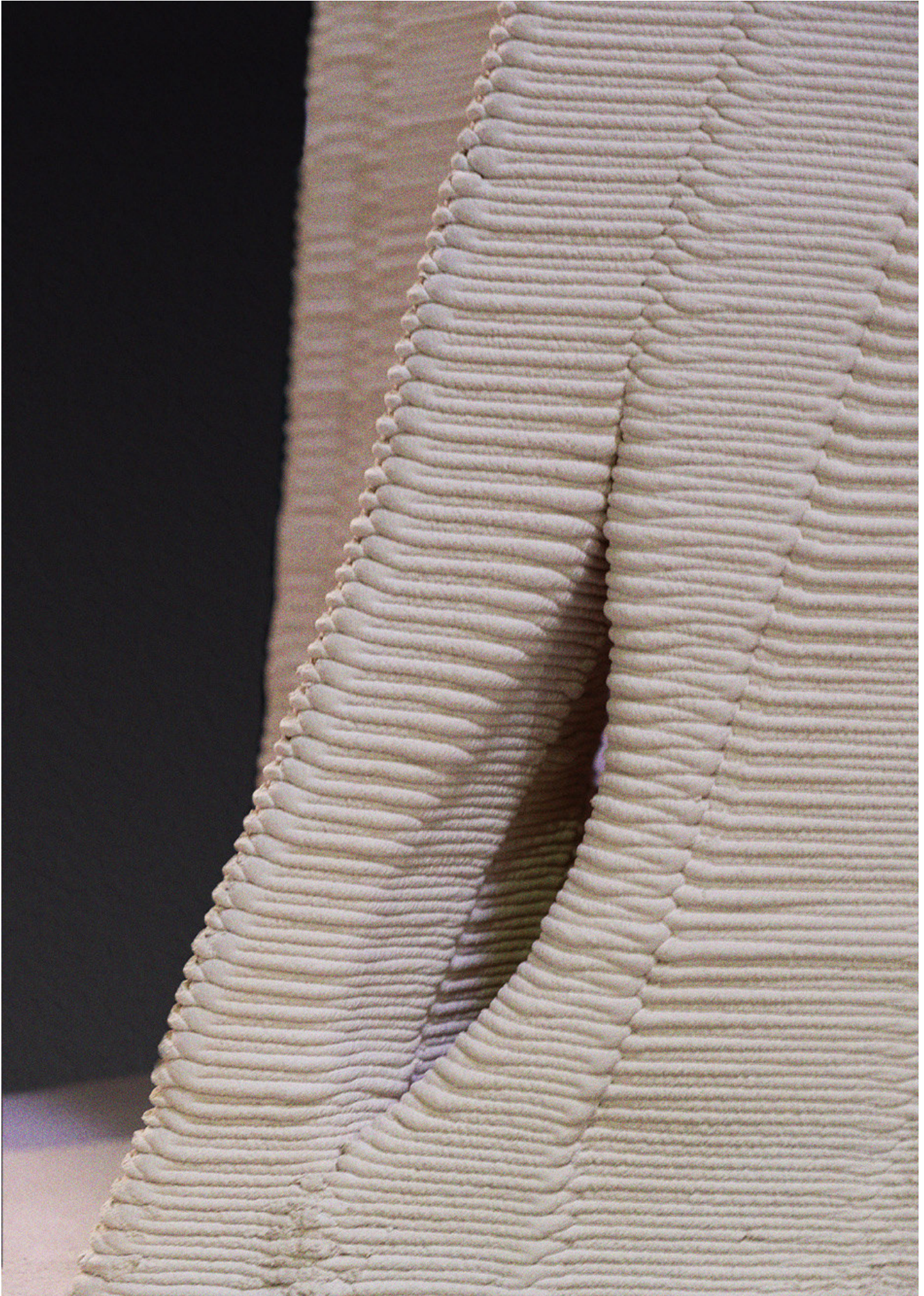

Diagram with Speed Mapping

Cave

Fabricated element
1:1 Scale



Jackdaw nest opening

Fabricated element
1:1 Scale

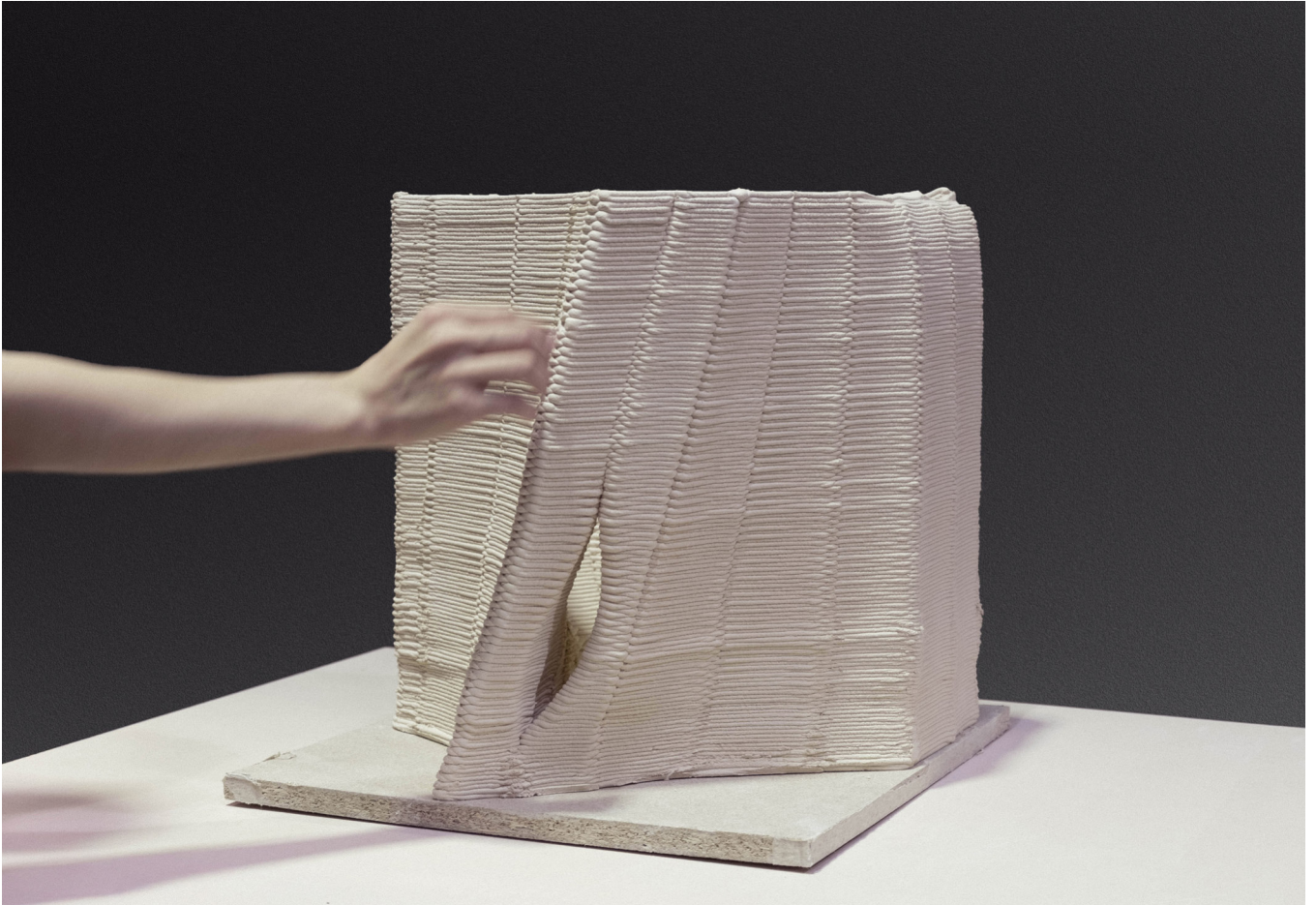

The Jackdaw Nest Tile after Firing

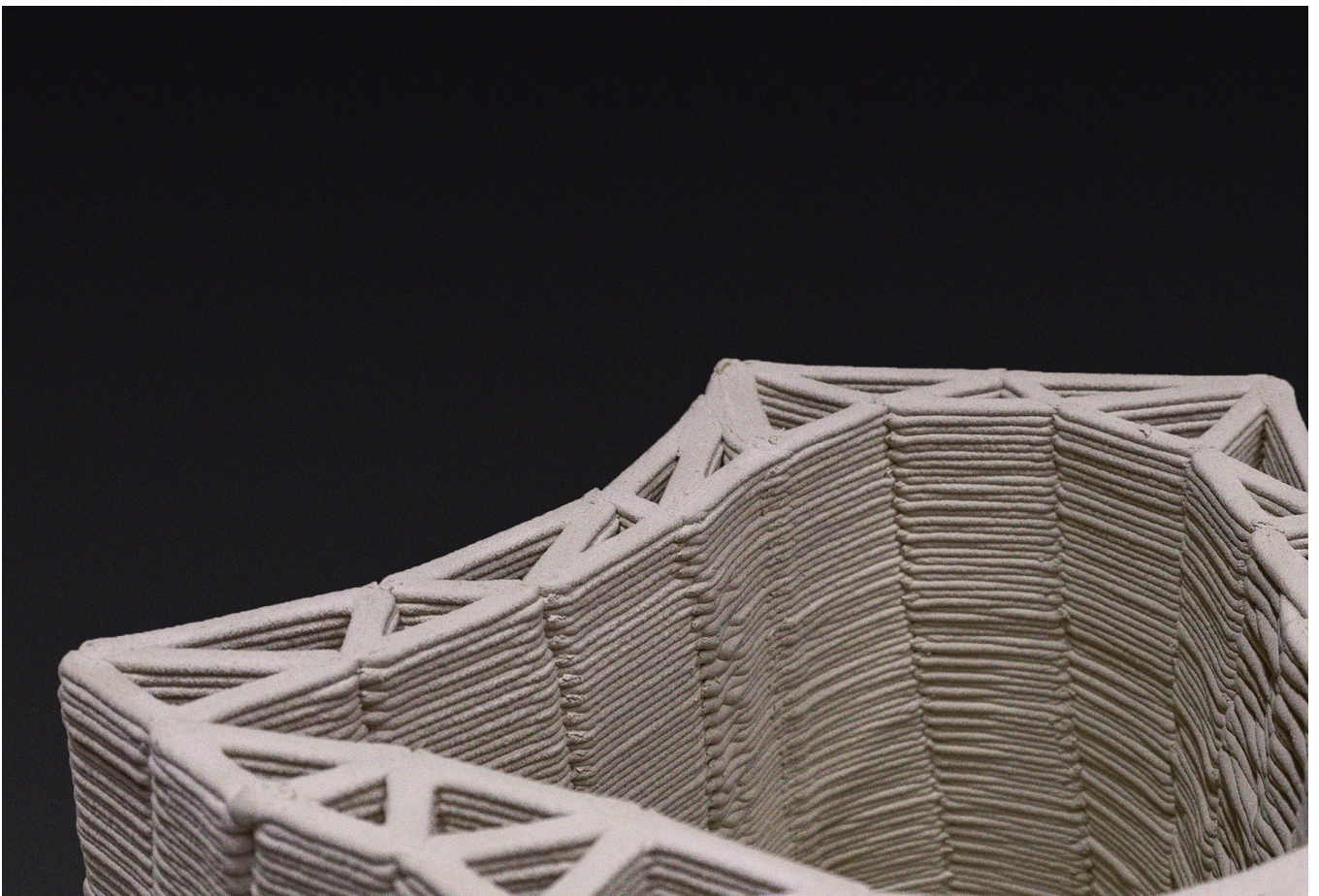

Detail of support structure which simultaneously forms inner and outer shell.

Shading Tile

In addition to the nesting tiles, our project includes climate-reactive tiles that share the same fin-like outer geometry but exclude the internal nesting cavity. These tiles play a key role in regulating the building's micro-climate. In summer, they act as shading devices, casting shadows across the facade to reduce solar gain. In winter, the hollow cavity inside the tiles functions as a thermal buffer, helping to moderate indoor temperatures.

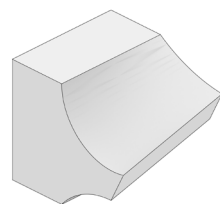
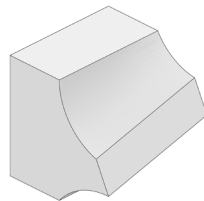
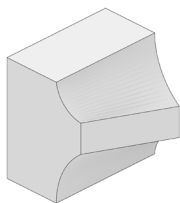
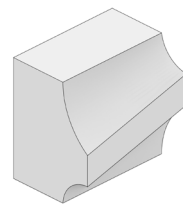
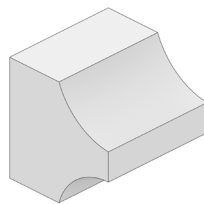
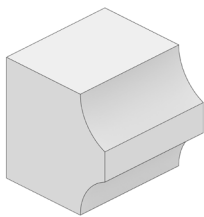
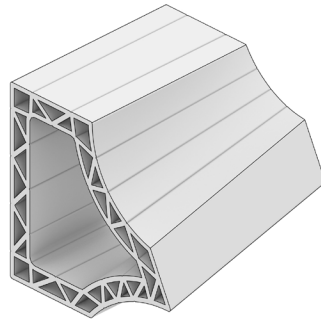

The tiles are parametrically designed to adapt to their specific position on the facade. Three key parameters define their geometry: the fin protrusion, adjusted based on orientation (greater depth for south-facing surfaces, for example); the overall tile depth, which influences the air volume inside and therefore the thermal buffering capacity; and the angle of the fin, which is tailored to optimize sun exposure, more horizontal on the south, more angled on the east and west.

Beyond their performance, these variations contribute to a unified aesthetic language. The shifting angles of the fins create a dynamic, wave-like pattern across the surface, an abstract reference to the nearby Danube River, and a subtle nod to the building's function as a water tower.

Sun Hour Simulation

In support of Ingolstadt's goal to become climate neutral by 2035, our design tackles the common challenge of facade overheating. Using climate analysis tools in Ladybug, we evaluated the façade's shading and cooling performance. The images below demonstrate a significant improvement in shading, resulting in noticeably lower facade surface temperatures.

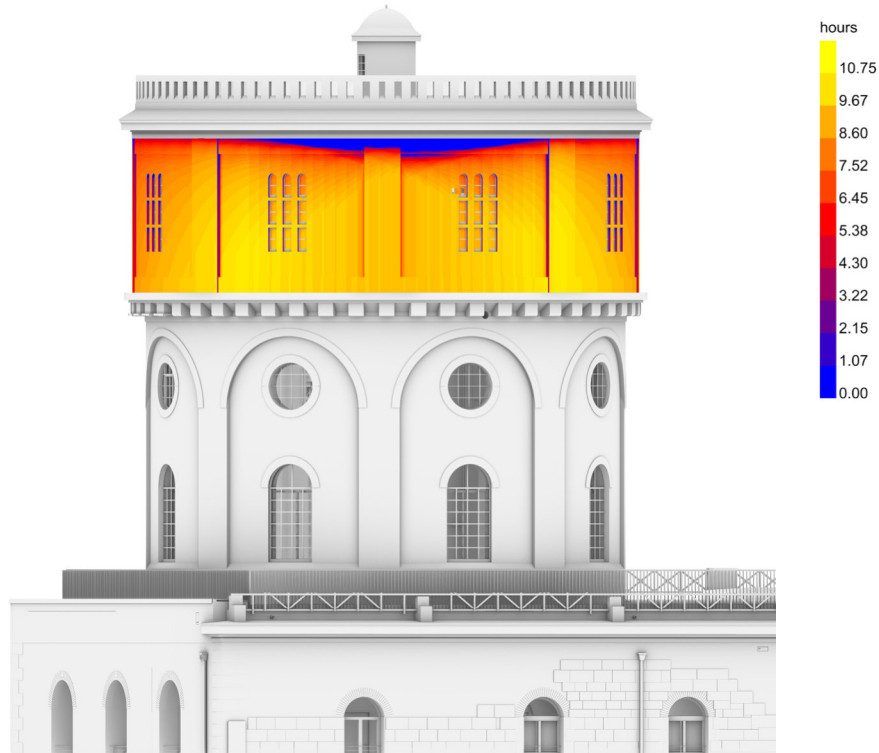

South West Sun Light Hour Analysis - Current Facade

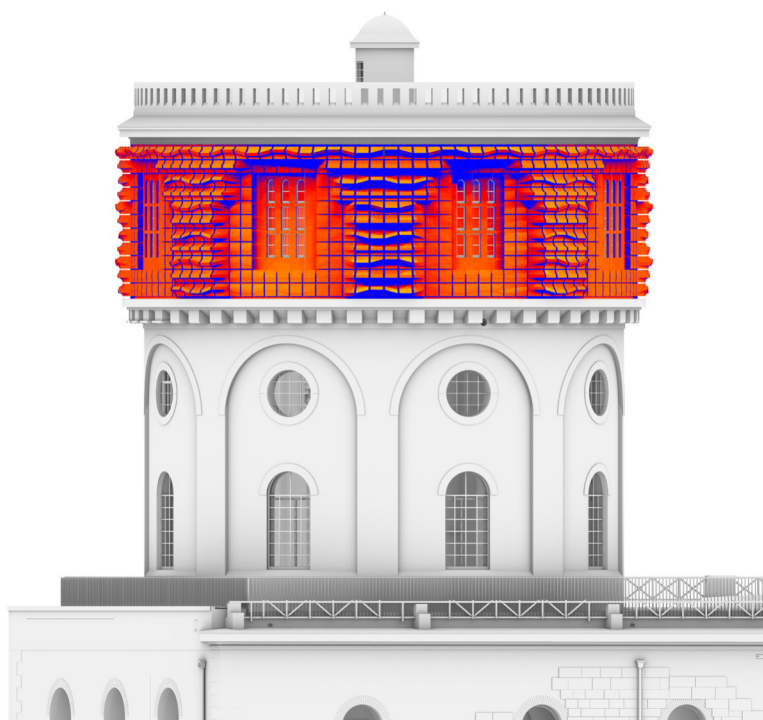

South West Sun Light Hour Analysis - Proposed Facade

Cave

Facade Design

The facade scheme illustrates the relationship between the nest tiles and the climate-responsive tiles. Curved transitional tiles bridge the gap between the sculptural fin shapes and the flat facade surface, creating a seamless and cohesive architectural language.

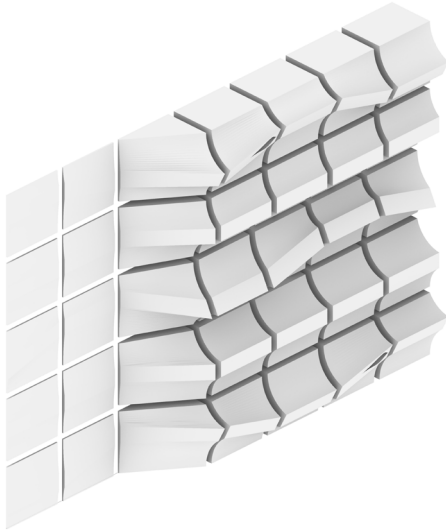

Ideal Jackdaw Nest Placements

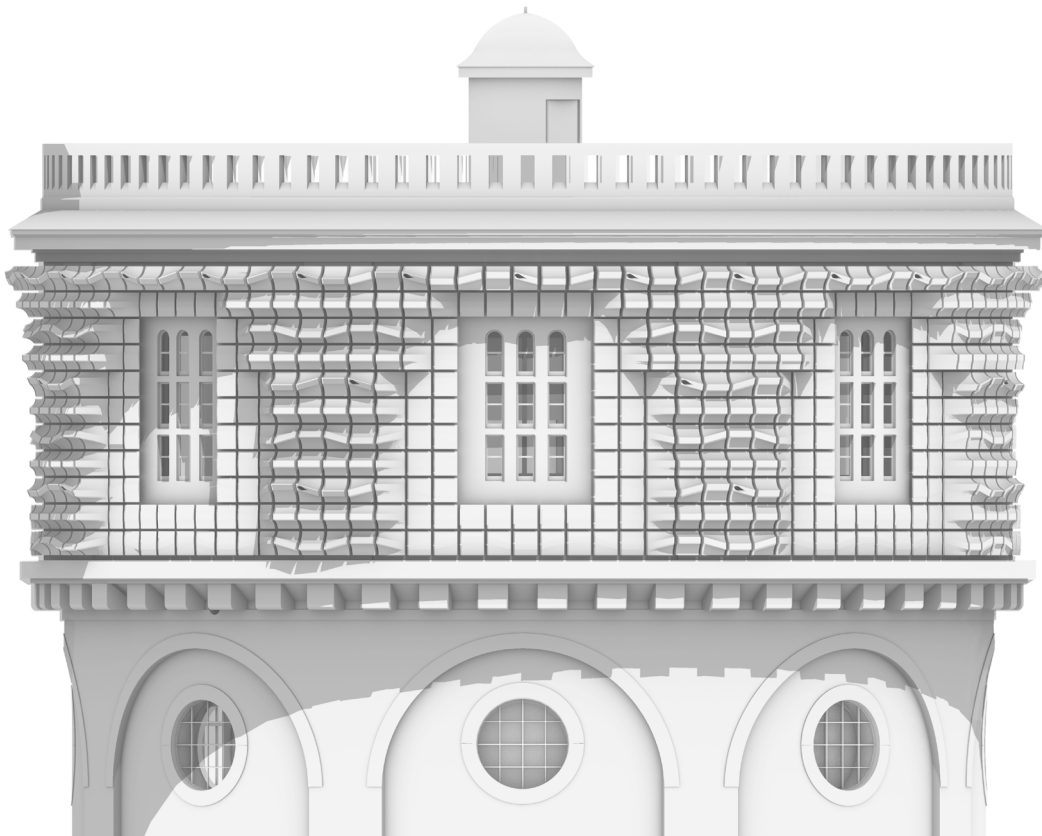

The curved elements of the facade pick up on the rhythm of the original arches in the water tower. By referencing these features, the new design creates a strong visual identity while respecting its historical roots.

A New Icon Rendering



South-East View of the Tower with New Facade

Project title: Birdy.

Group members: Michelle Mattes, Sacha Rahem, Ambroise Salles, Anne Schlumbohm

Project description: “Birdy” is a design strategy that reactivates abandoned buildings in Ingolstadt by connecting birds, architecture, and people through a modular tile system. Working across multiple scales – from the city map to the façade to the individual nest - the project uses 3D-printed clay tiles to provide species-specific nesting spaces for kestrels and barn owls. These interventions transform abandoned buildings into habitats and form part of a walkable urban trail that raises ecological awareness. By addressing both biodiversity and spatial reuse, “Birdy” reframes architecture as a shared system – responsive, inclusive, and alive.



Main installation on the tower

Species Portrait

Kestrel

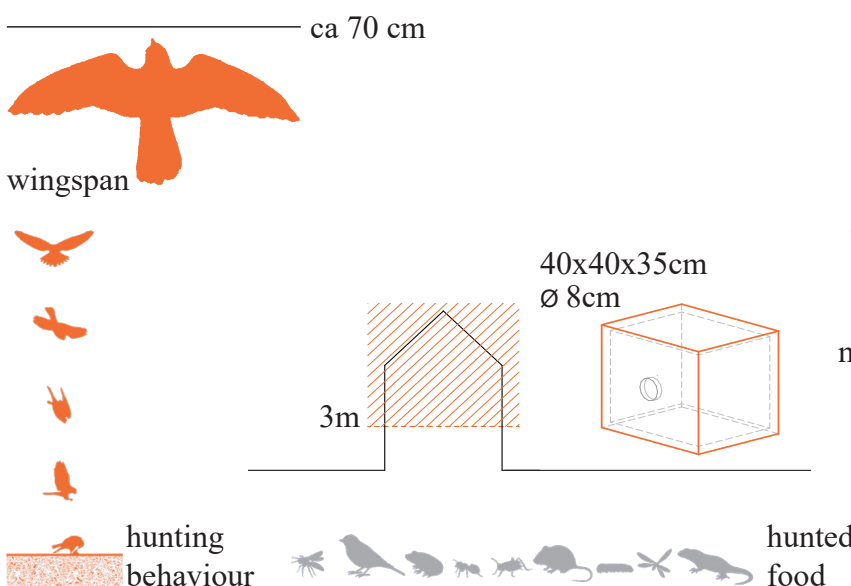

Barn Owl

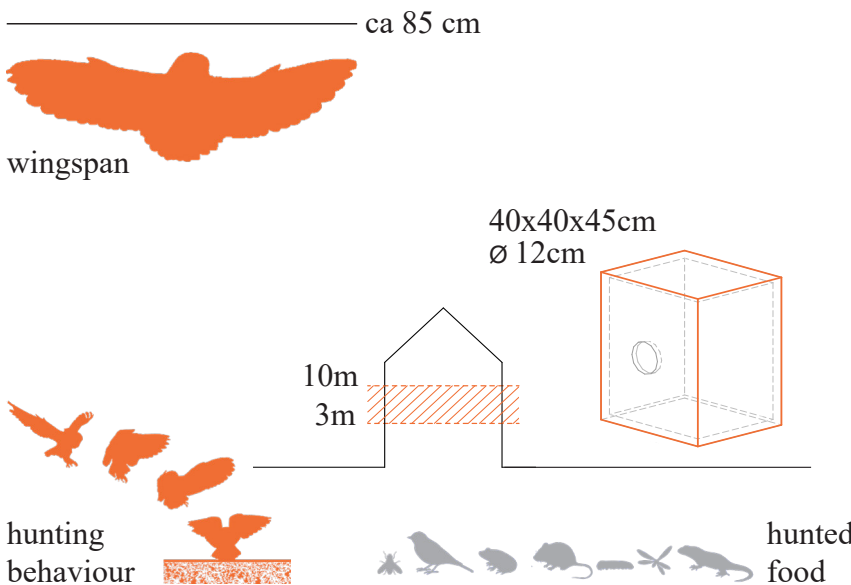

Birdy

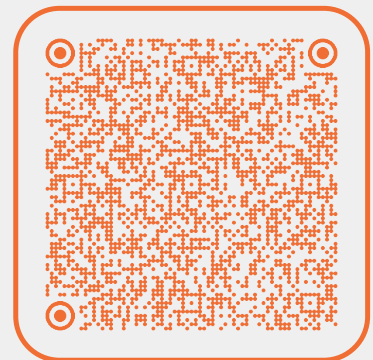

meet the birds!

Birdy – Discover the hidden birdlife of your city!

With the “Birdy” app, you can explore the bird path, discover already installed nests on an interactive map, and learn fascinating facts about kestrels, barn owls, and their natural habitats. Scan buildings around you to find out where new nesting sites could be possible.

Discover. Understand. Protect.



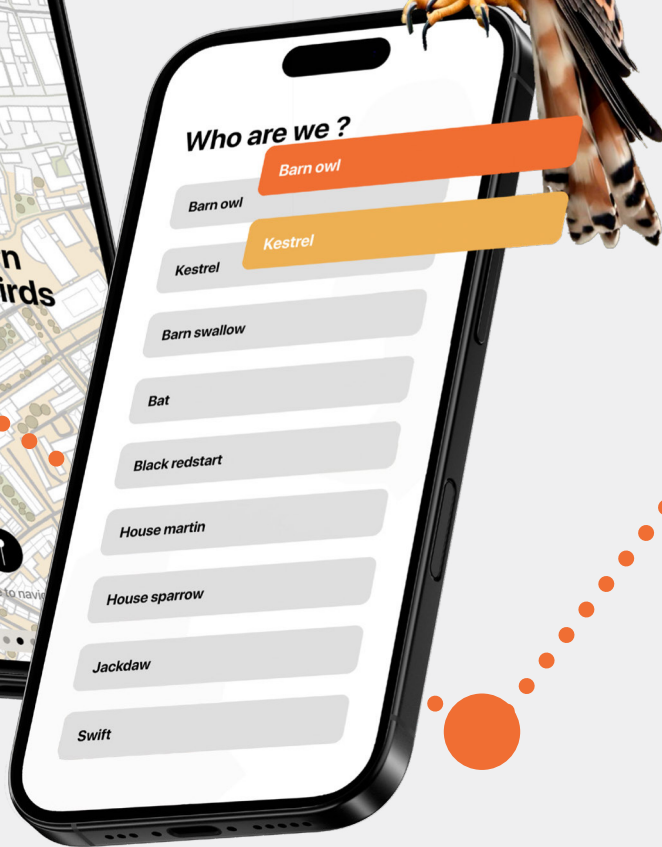
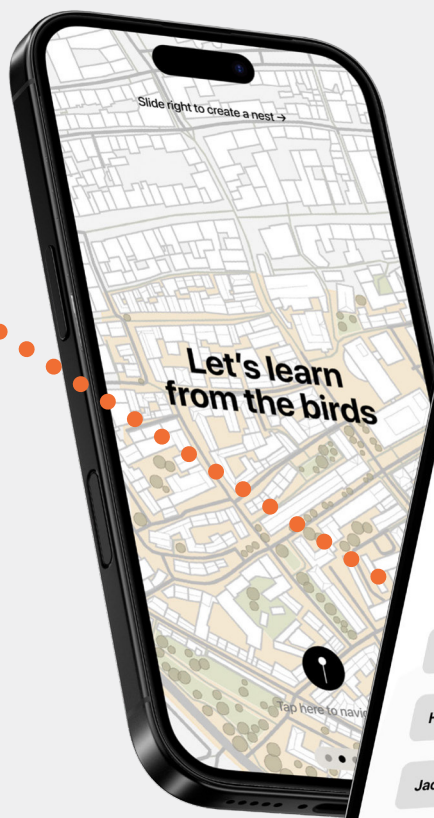

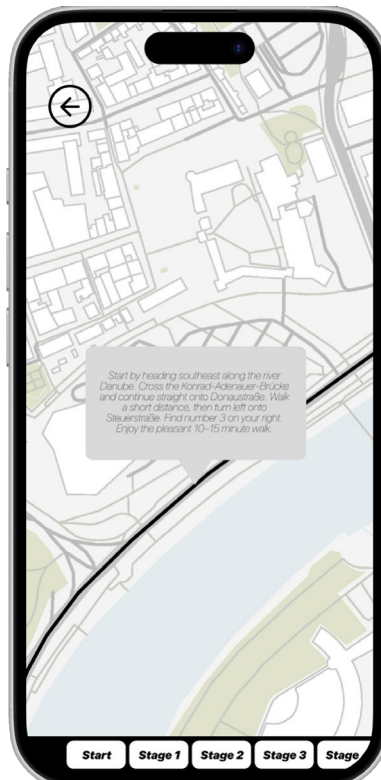

interactive map

exploration path

buildings

Interactive App

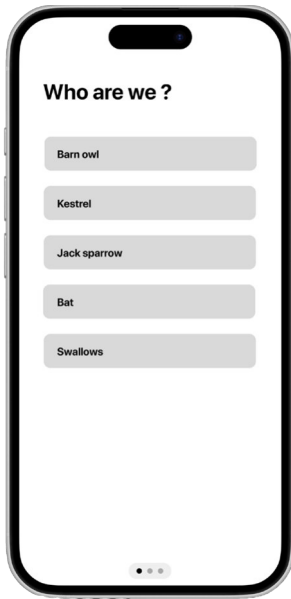

swipe right

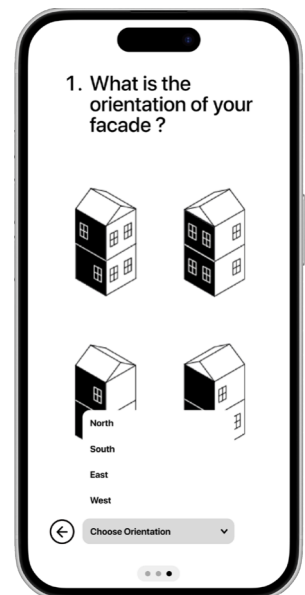
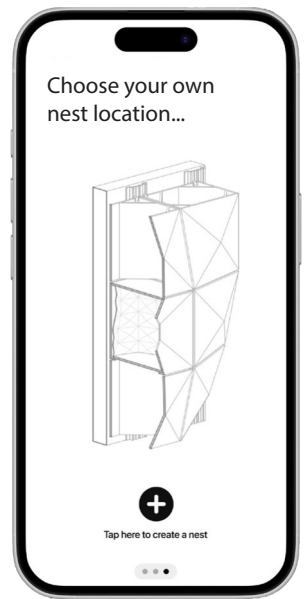

swipe left

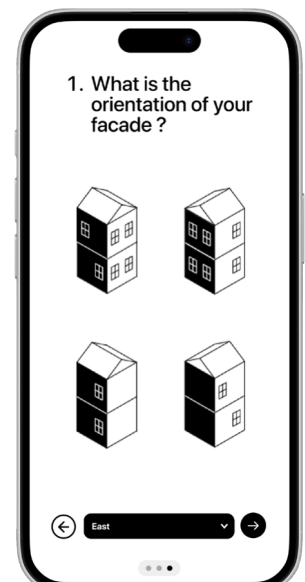

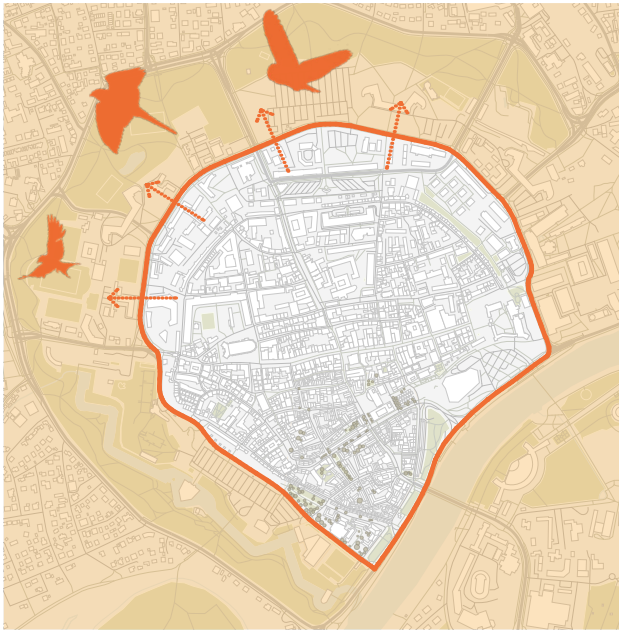

loss of biodiversity within the city

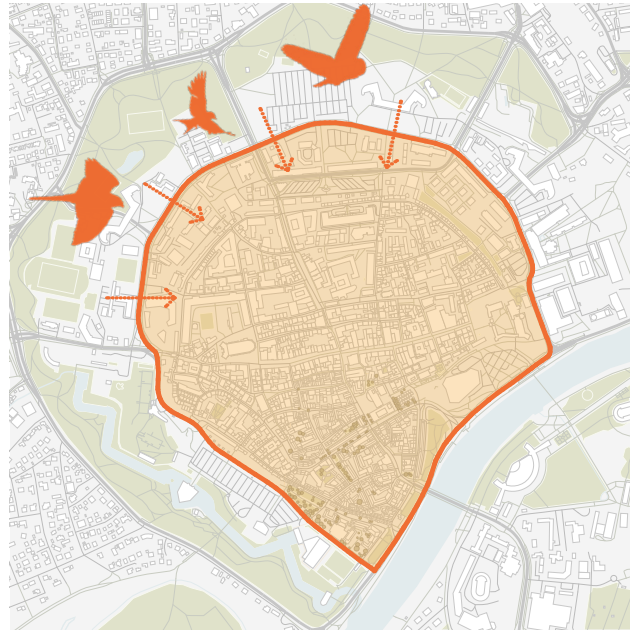

integration of wildlife

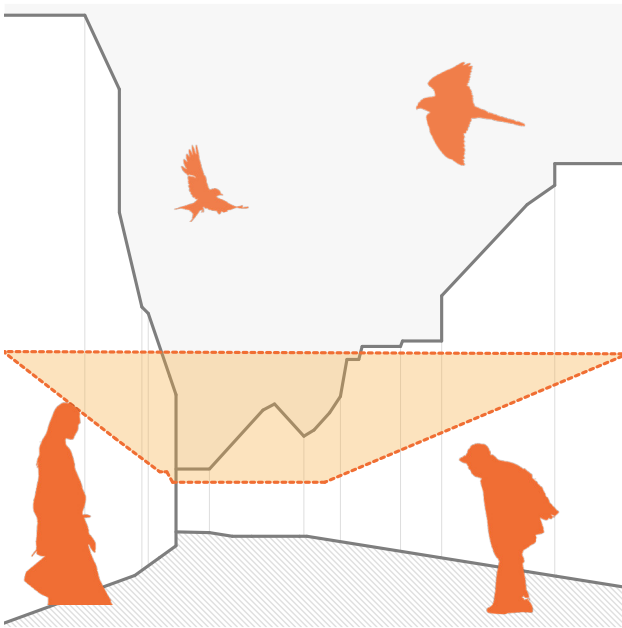

loss of awareness for wildlife in the city

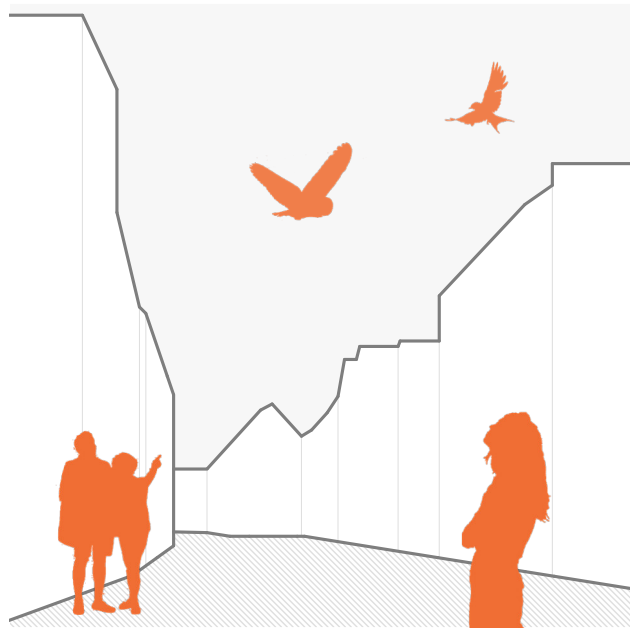

creating awareness through education



abandoned buildings

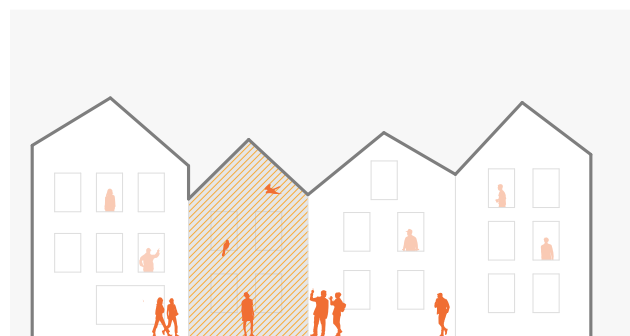

"occupation" of abandoned buildings

DALWIGK - Water Tower

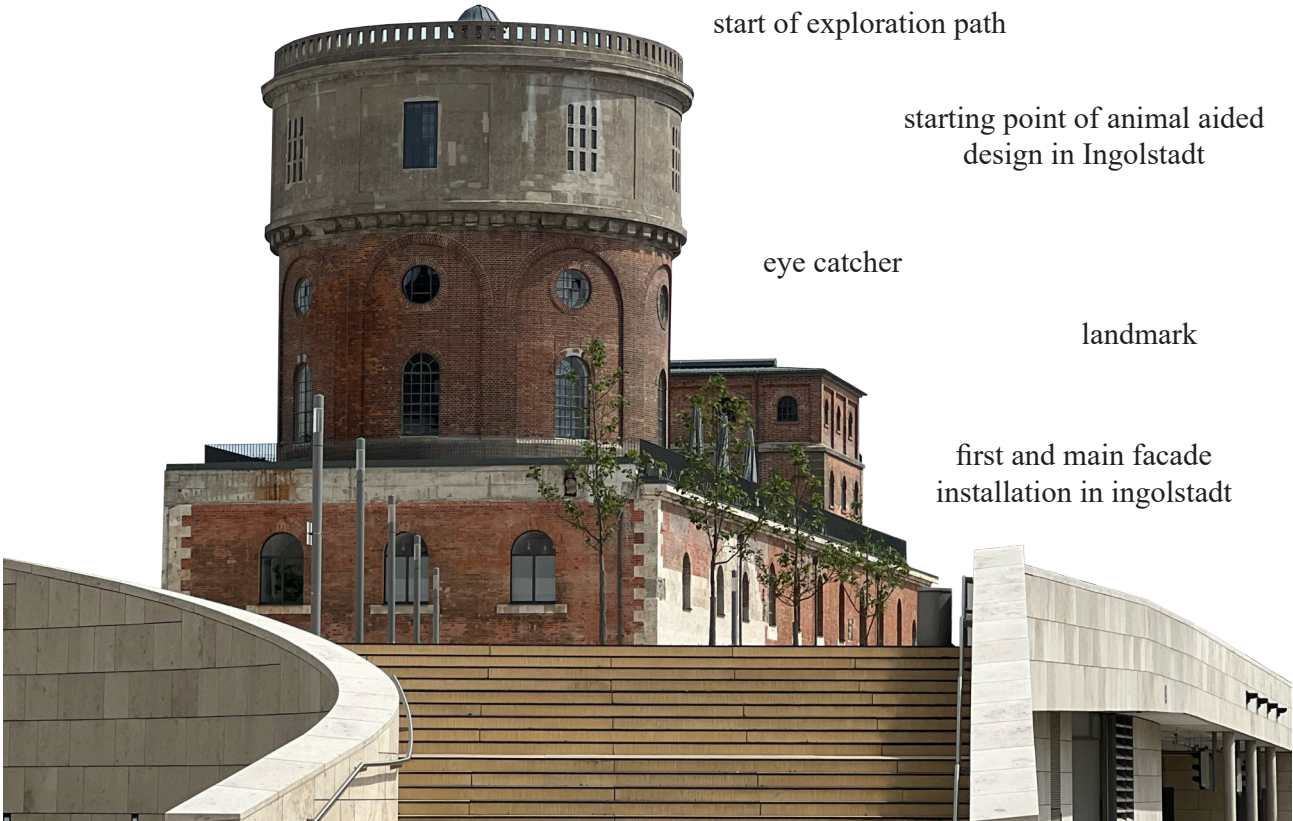

start of exploration path

starting point of animal aided design in Ingolstadt

eye catcher

landmark

first and main facade installation in Ingolstadt

Abandoned Buildings



in city centre

temporarily not used

abandoned barns

Multiscale Approach

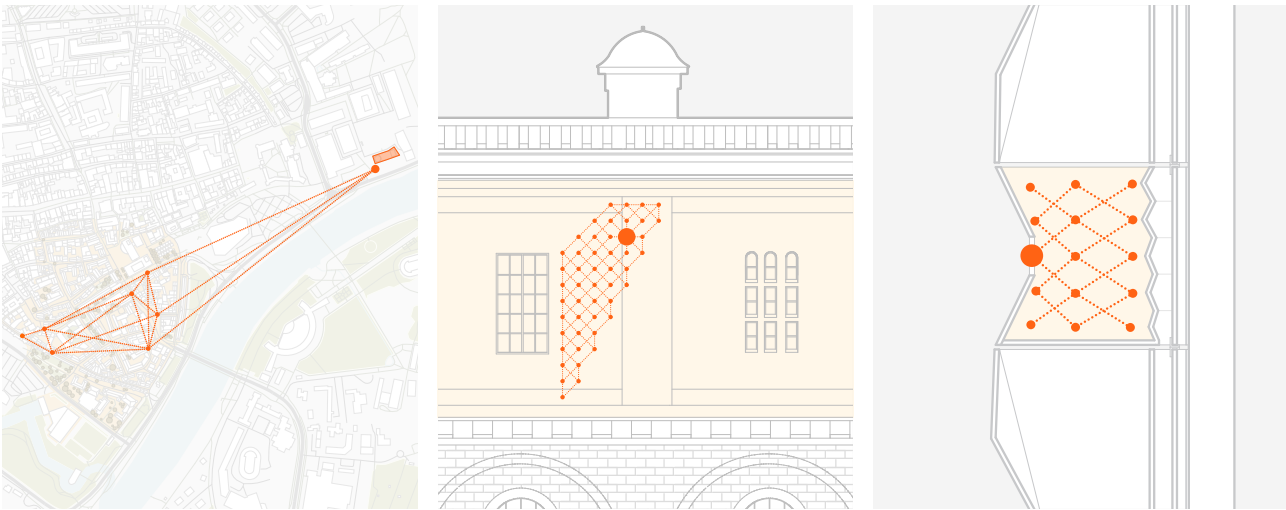

city scale
ingolstadt plan

facade scale
tower elevation

facade element scale
tile section





Multiscale Approach.

The project operates across three interconnected scales: city, façade, and tile. At the city scale, a walkable path links abandoned buildings as anchor points in a network of potential habitats. At the façade scale, each wall becomes a grid informed by the nesting needs of kestrels and barn owls, with tile placement guided by orientation and sun exposure. At the tile scale, the inner structure connects points to create a stone-like surface that mimics natural nesting conditions.

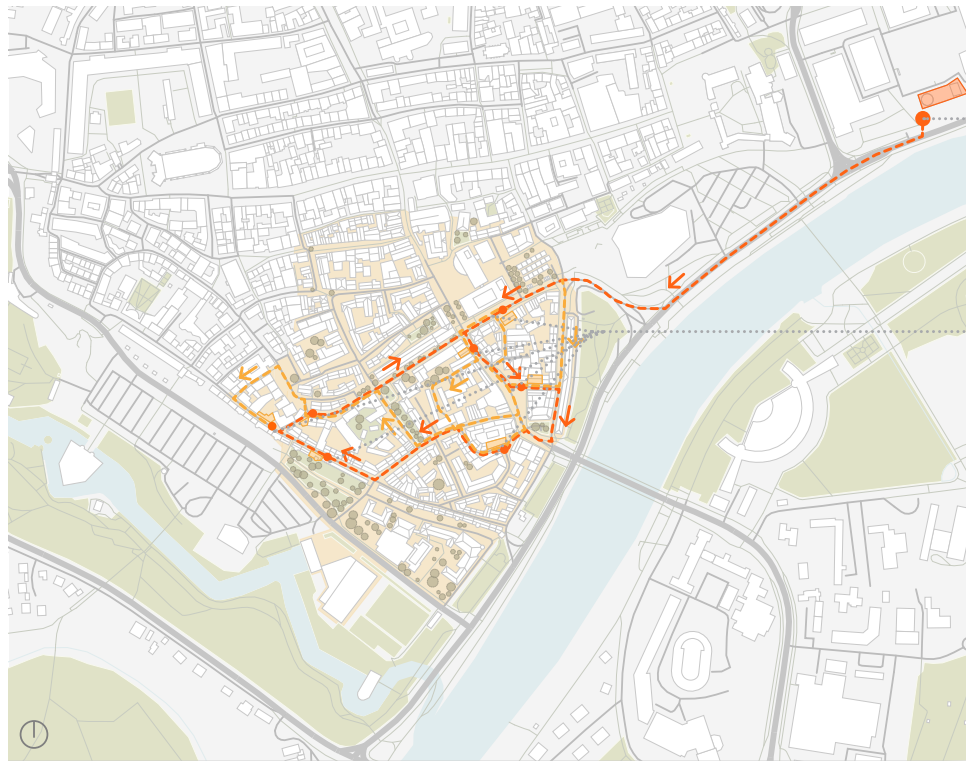
Multiscale Approach

Exploration Path





- water tower 
- aband. buildings 
- main path 
- discovered path 
- stations 

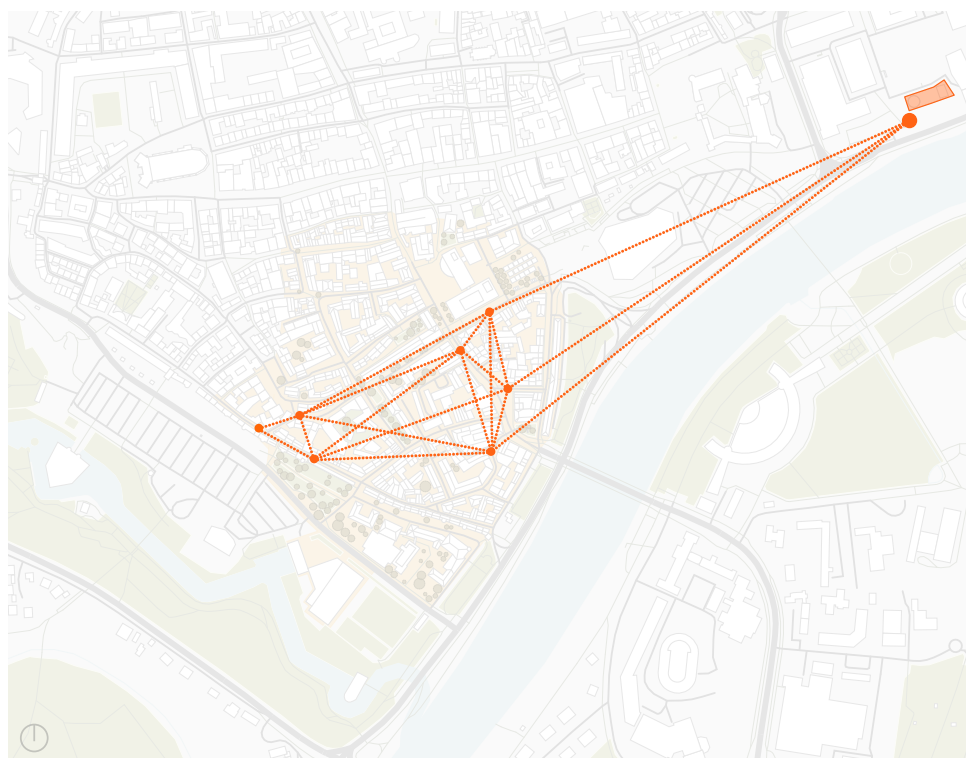

Connection Net



- city scale selected area 
- connection net 
- stations 

Facade Scale

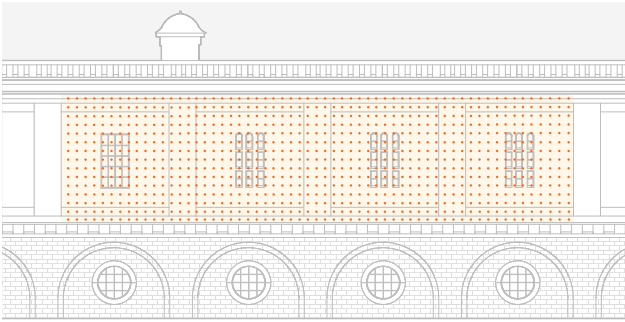

1. creating a grid

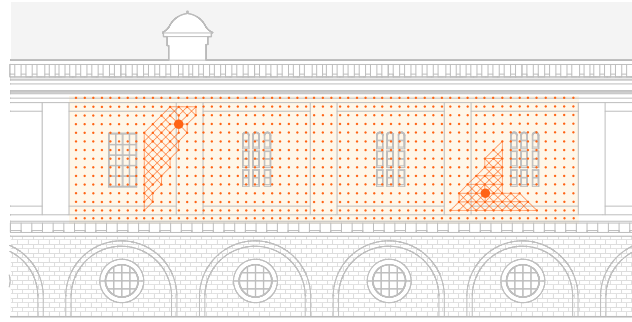

2. defining positions of nests based on species requirements

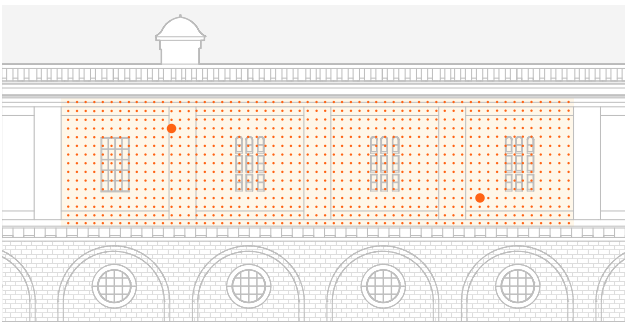

3. connecting points around the nests to emphasise their positions



4. final shape

Facade Scale

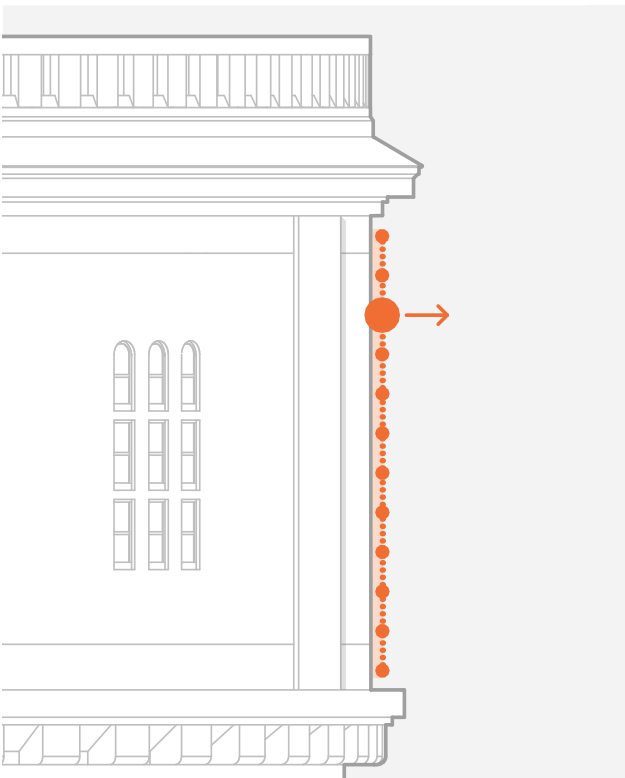

5. flat grid

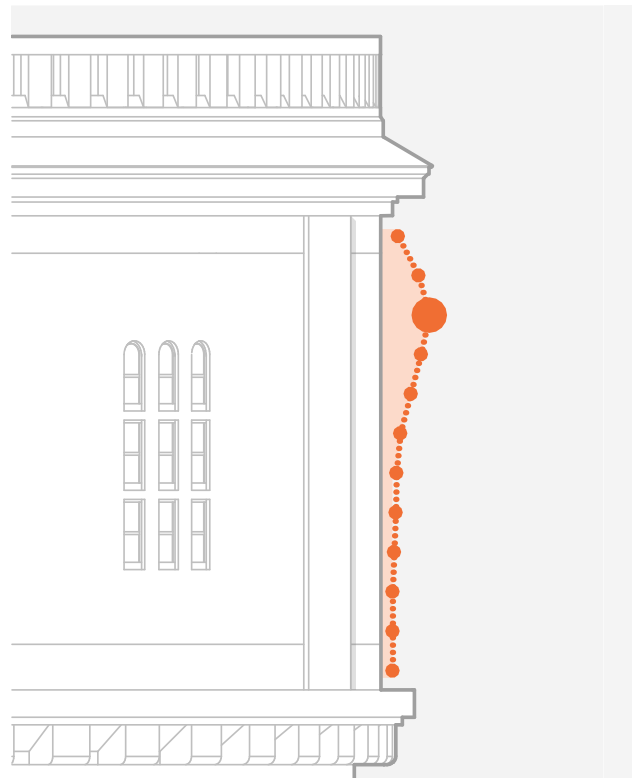

6. pulled out nest

Multiscale Approach

Axonometry

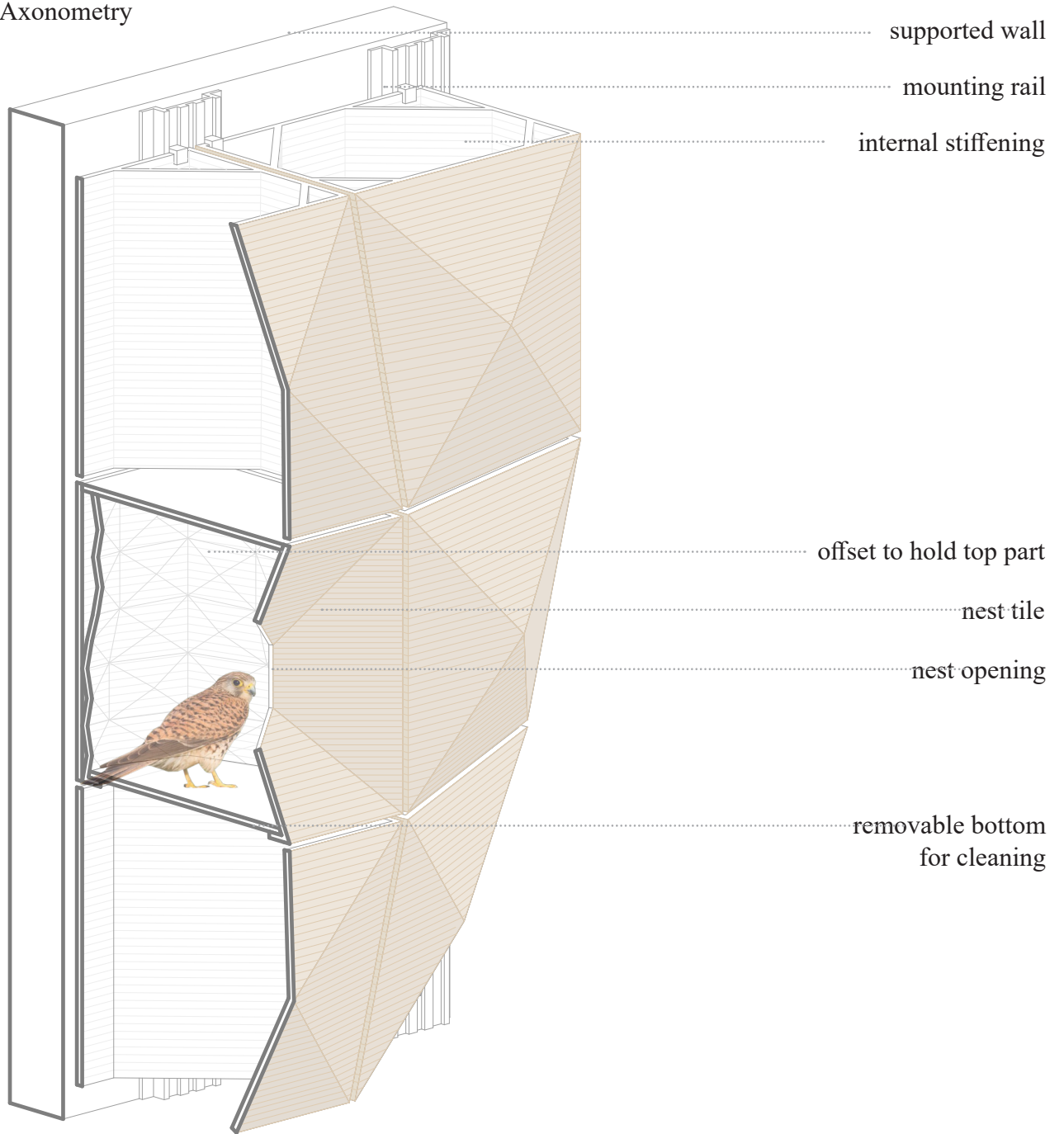

Mounting

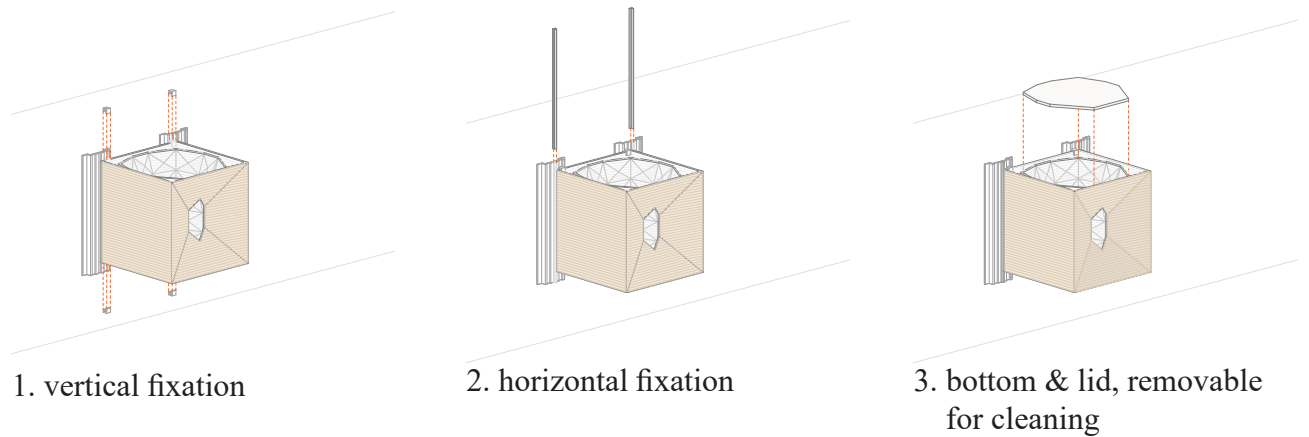



Application water tower

Proposed design water tower

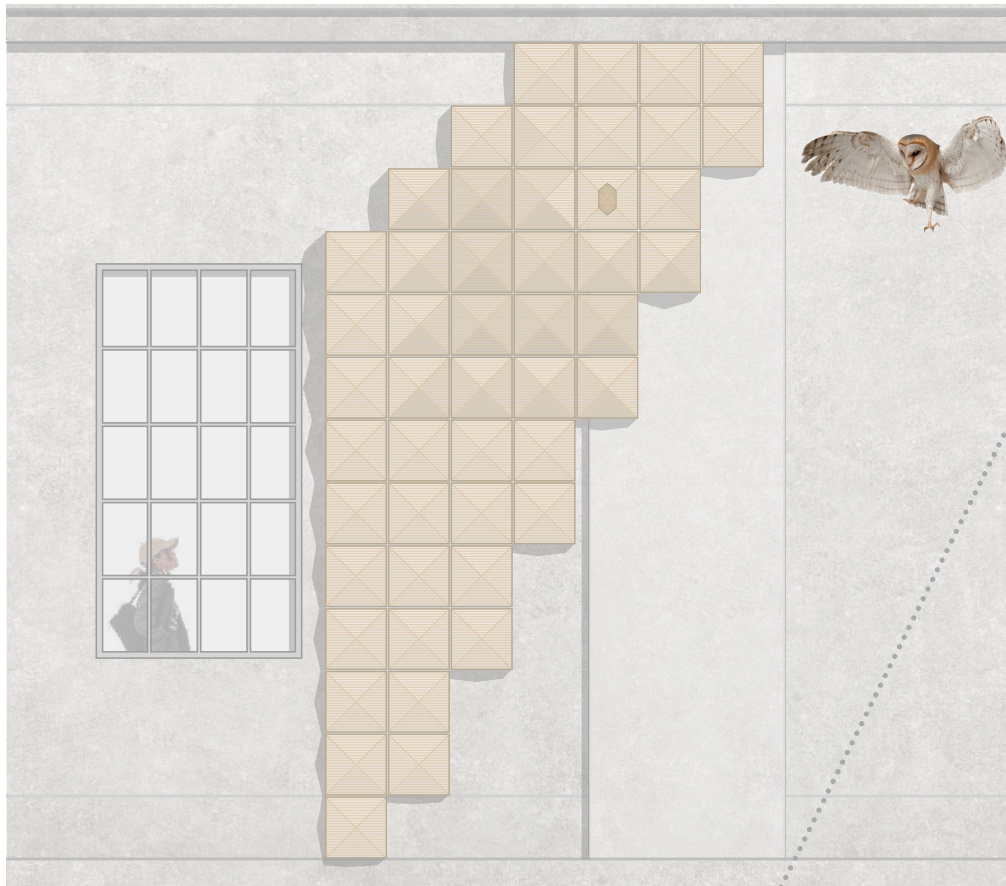

South - west elevation

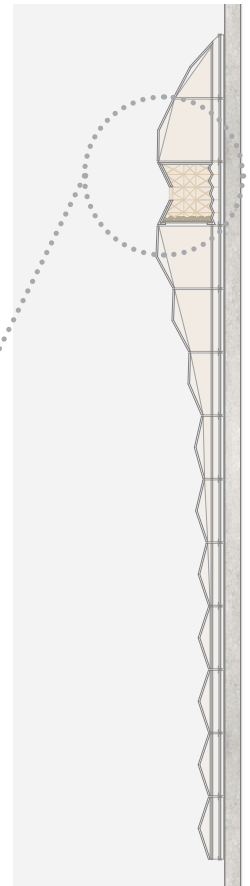

Section

1m



Overview city

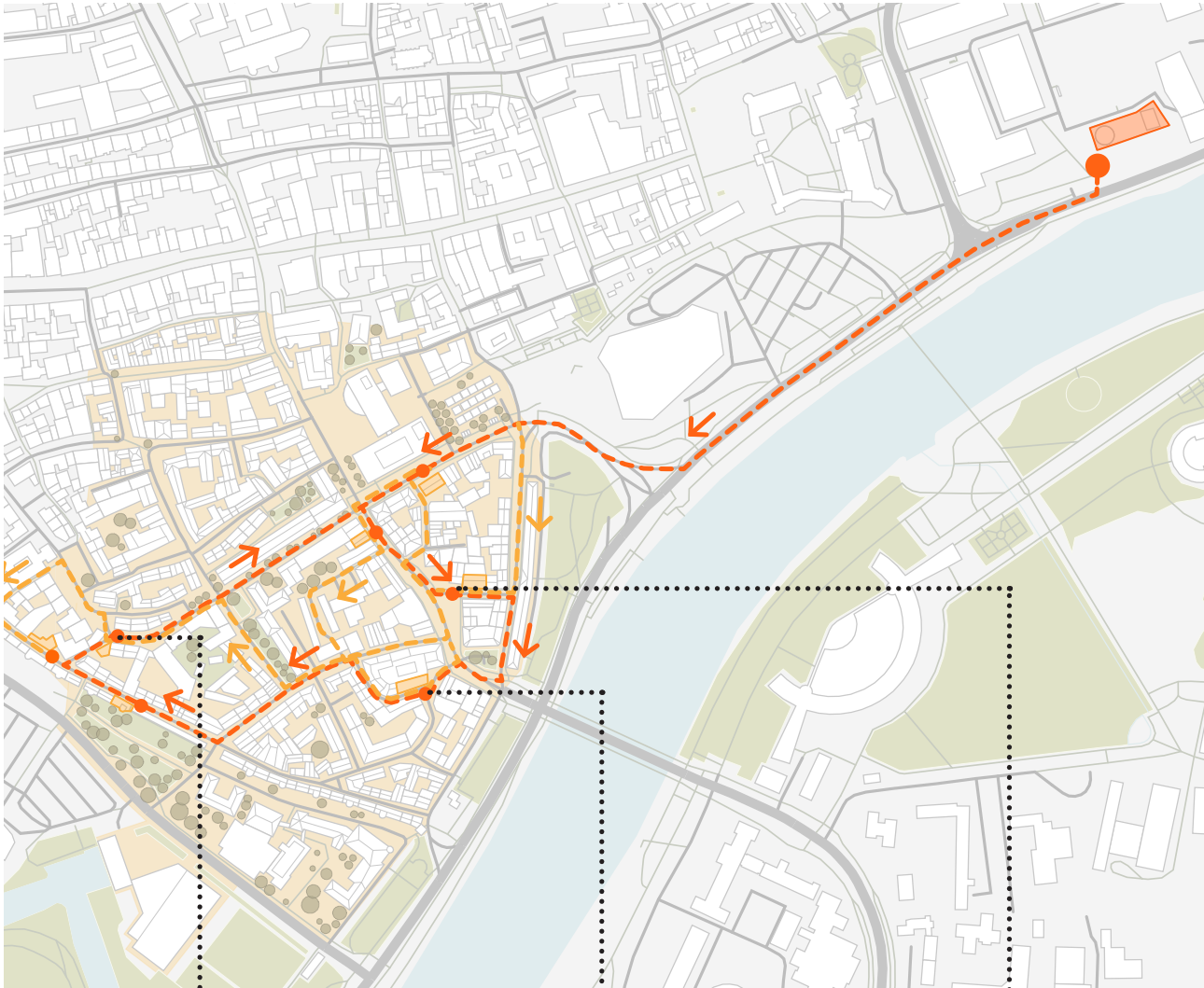

Design development

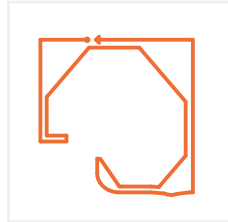
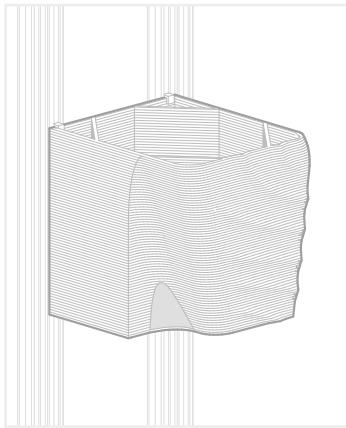

Concept 01

stage: midterm
print: not printed
problem: overall concept & lack of complexity for print

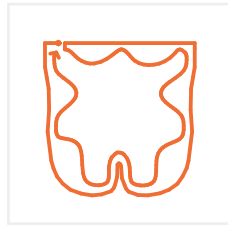
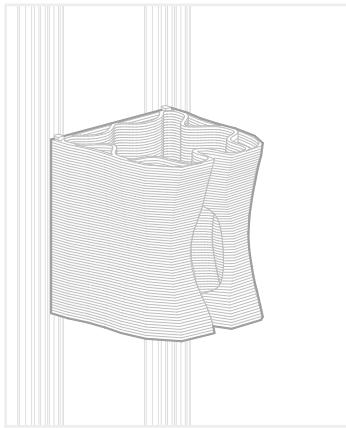

Concept 02

stage: printing session 1
print: printed
problem: overall concept & printing issues

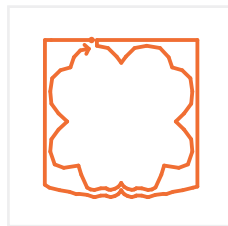
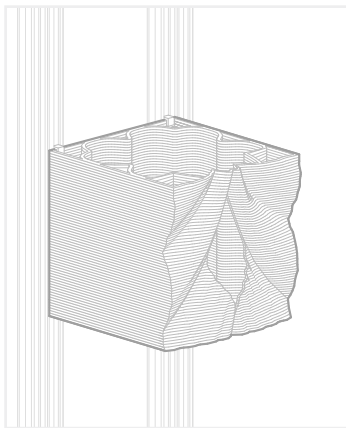

Concept 03

stage: printing session 2
print: printed & glazed
problem: overall concept & printing issues

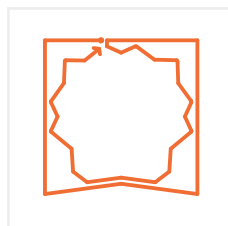
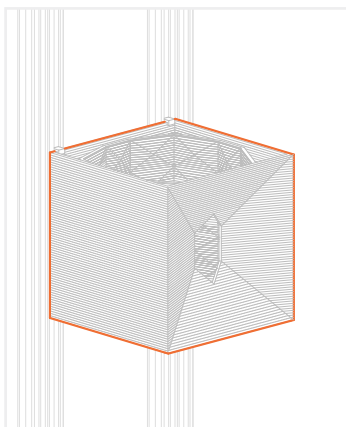

Final concept

stage: today
print: not printed

Birdy.

3D Printing studies

Printing session 1

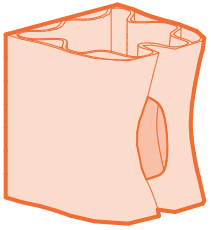

research questions

- large overall shape? - limitations?
- internal structure → overall stability?
- size and shape of the opening?

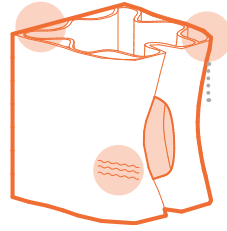

methods

- pipe touched the corner
- “arch” unstable, required manual support
- printing flow stopped intermittently without clear reason
- inner structure did not fully connect to outer shell



Option 1
collapsed!



Option 2
collapsed!



Option 1.2
worked!

Printing session 2

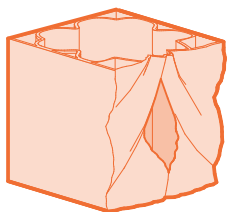

research questions

- complexity across different scales of surface?
- improvement of shape of opening to enhance stability?

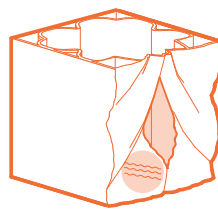

methods

- “arch” printed significantly better this way
- printing flow still stopped intermittently, despite changing printing direction



Option 3
worked!

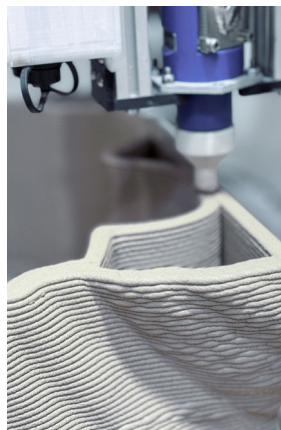

Surface

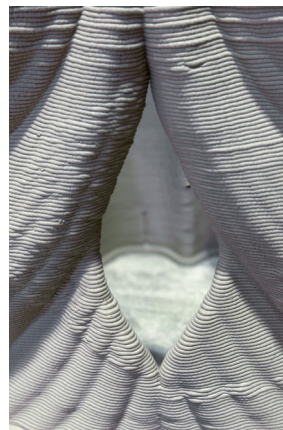

Opening

Final Tile



printed and glazed tile



detail bottom



detail hole



detail corner

Nest and Flow.

Project title: CohabiTiles - Nest and Flow

Group members: Ilay Altinelli, Ameli Dammann, Sofia Esperanza Figueroa Araneda, Tuvanna Gül

Project description: CohabiTiles is a 3d printable modular clay tile system designed to support urban biodiversity while responding to the needs of architectural renovation. Developed for Ingolstadt's most common bird species—the house sparrow and the swift - CohabiTiles transforms facades and roofs into shared habitats. The system consists of two complementary elements: the Nest, which provides climate-conscious nesting spaces, and the Flow, which encourages natural ventilation and shading. Drawing inspiration from traditional monk-and-nun tiles, the design balances water flow, thermal performance, and architectural integration. A parametric opening system adapts each Nest to the spatial and behavioral needs of different birds. CohabiTiles offer a simple yet effective way to bring ecological value back into the built environment.



CohabiTiles | roof system

Species Portrait

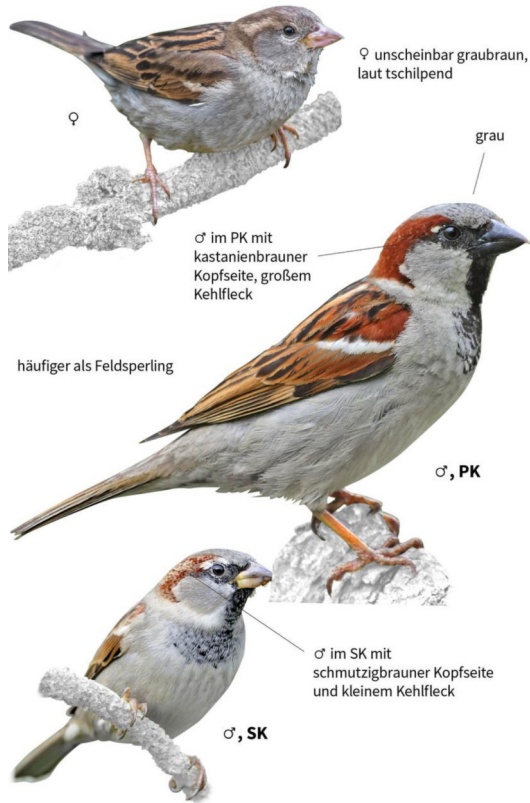

size: 140 – 160 mm

wingspan: 190 – 210 mm

rain/wind protection is important

non-migratory, local movements

lives in colonies

nest size: 12 cm x 12 cm

nest height: > 2-3m

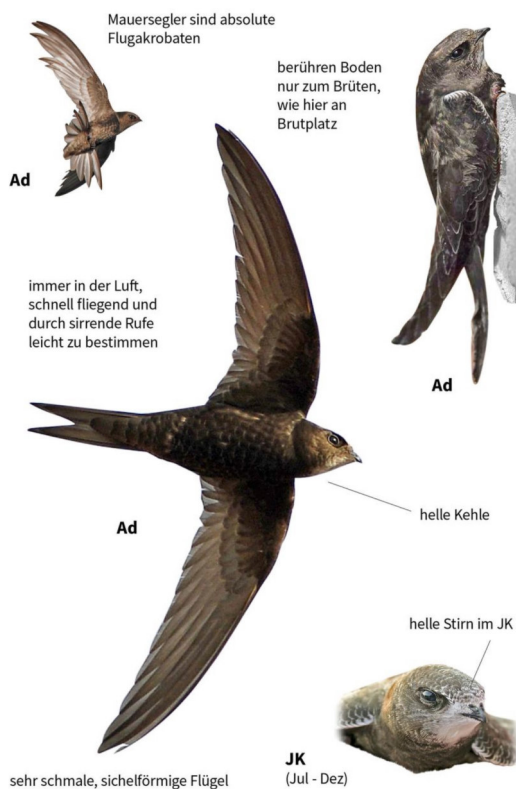

size: 140 – 160 mm

wingspan: 190 – 210 mm

rain/wind protection is important

non-migratory, local movements

lives in colonies

nest size: 12 cm x 12 cm

nest height: > 2-3m

CohabiTiles

Nest and Flow.

Research



Design References

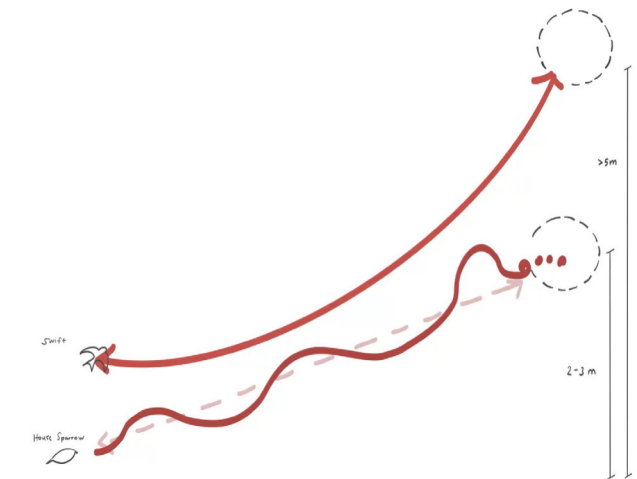

Behaviour Analysis Diagram: Flight Path



Design References

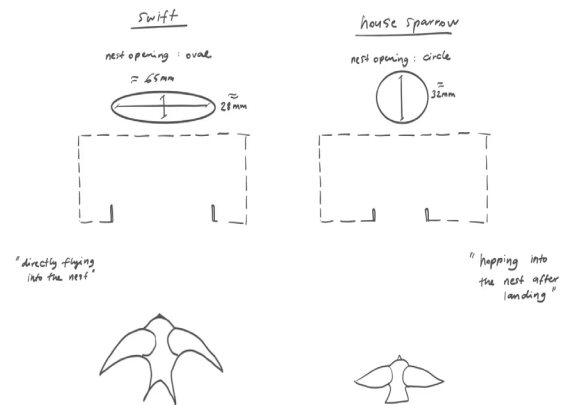

Behaviour Analysis Diagram: Entering the Nest



„Mönch und Nonne“ : Adopted Qualities

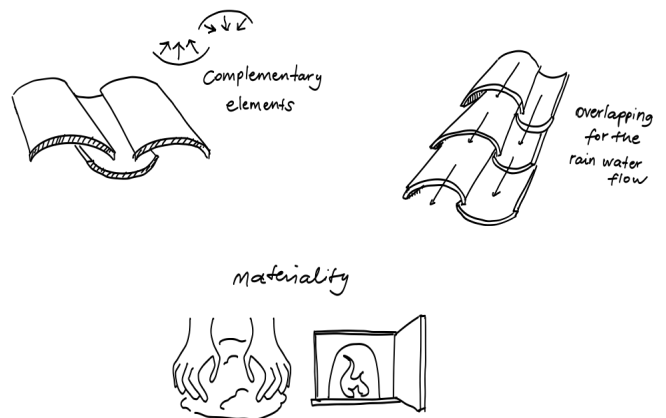

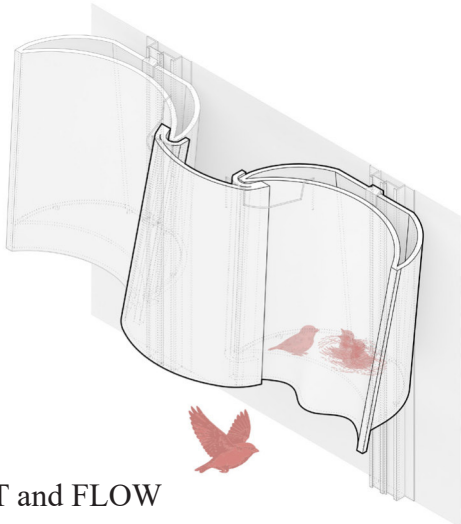

NEST and FLOW

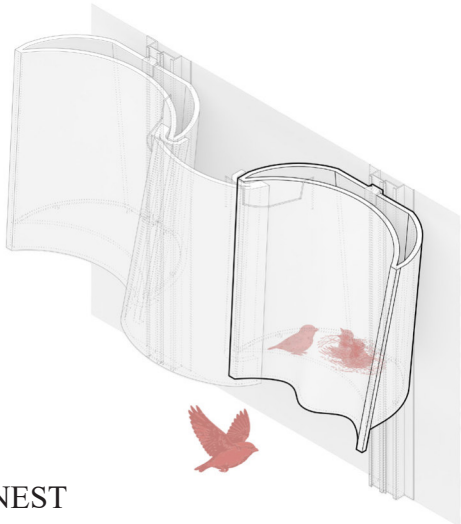
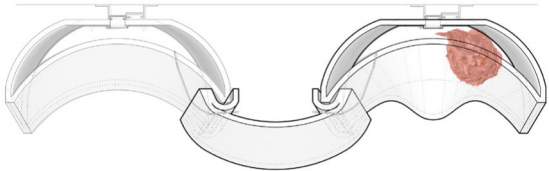

The NEST

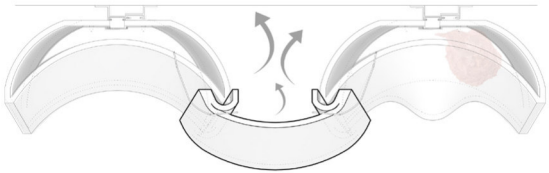
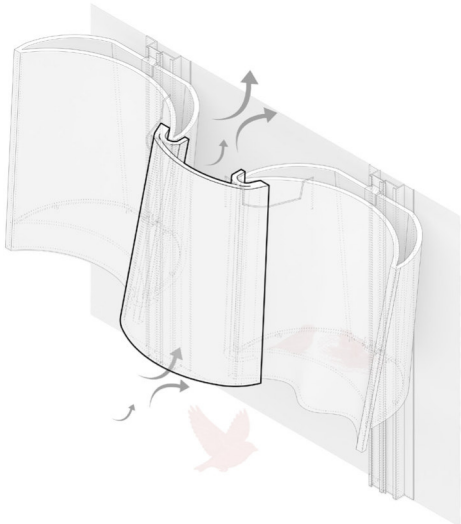
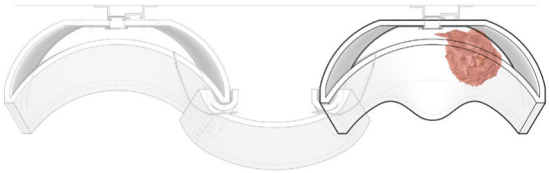

The FLOW

CohabiTiles

Nest and Flow.

Parametric Design

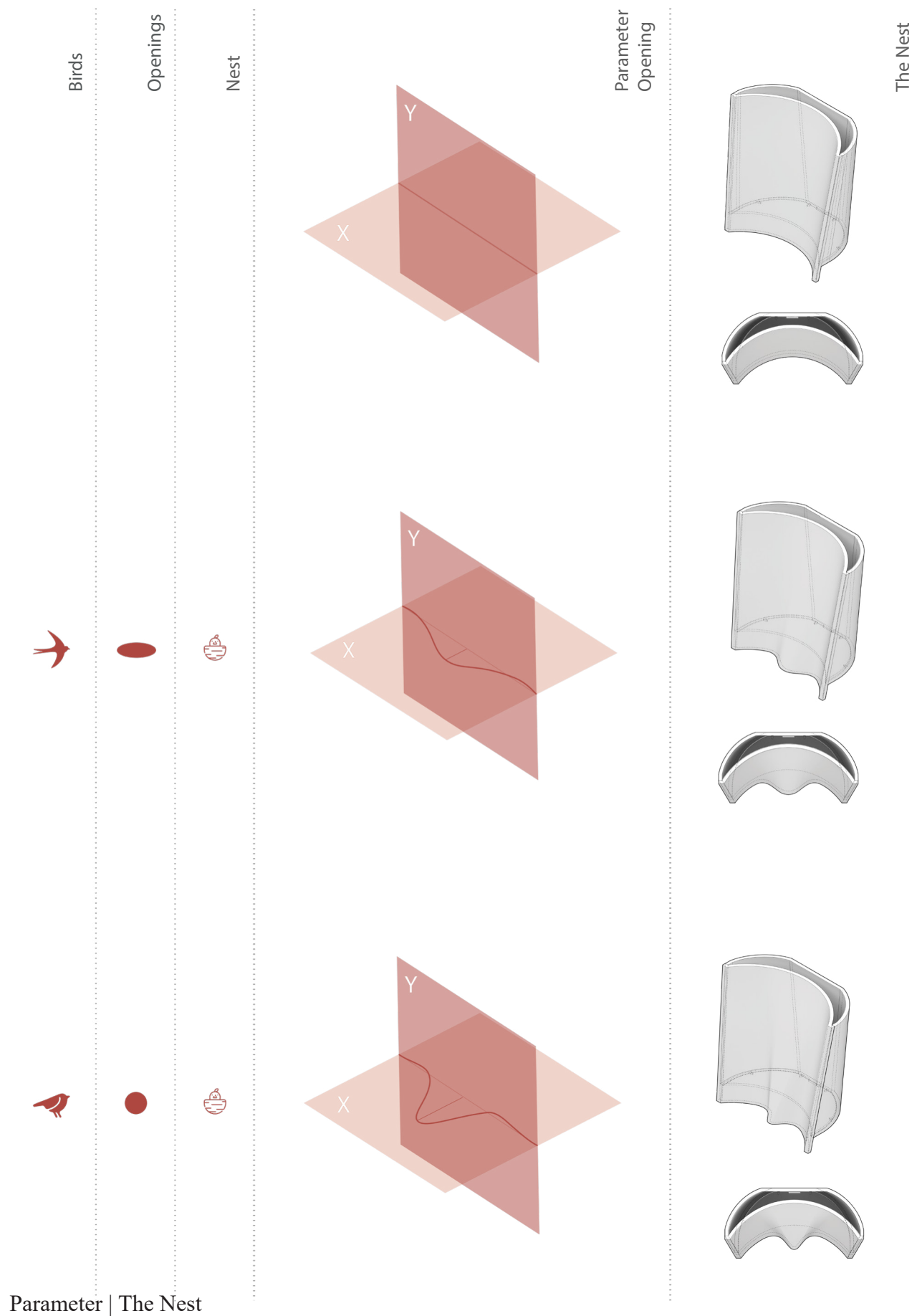

dB dB Airflow



Warming



Shading

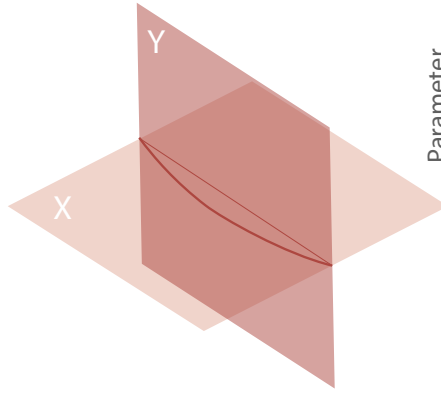

Parameter Opening

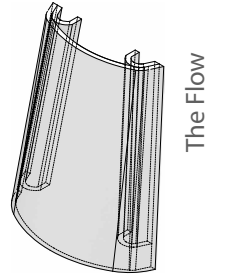

The Flow

dB dB

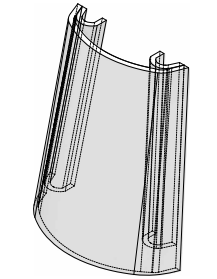
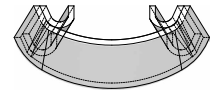
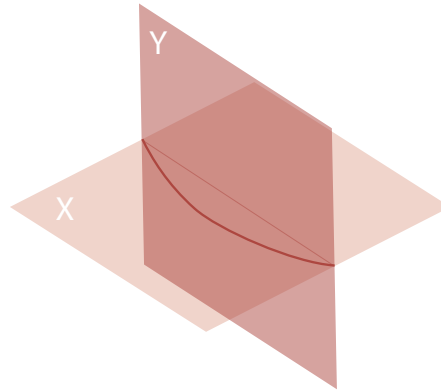

dB dB dB

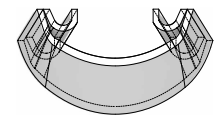
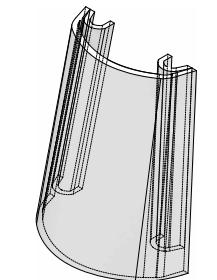
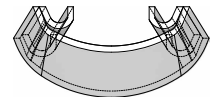
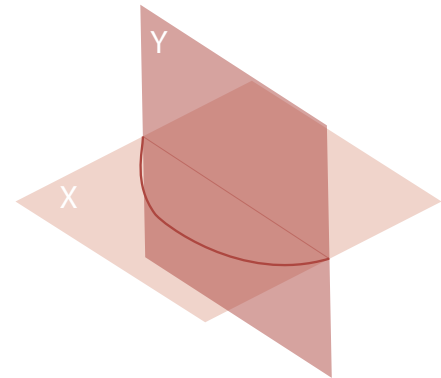

dB dB dB dB

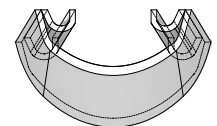
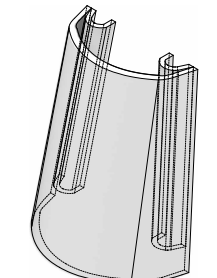
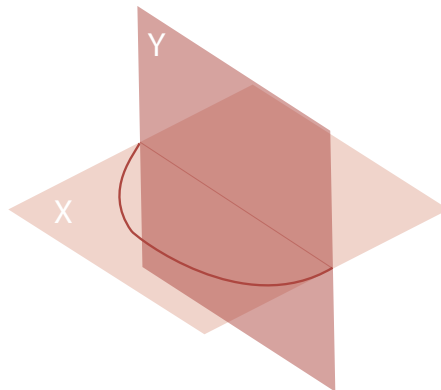

Parameter | The Flow

CohabiTiles

Nest and Flow.

CohabiTile

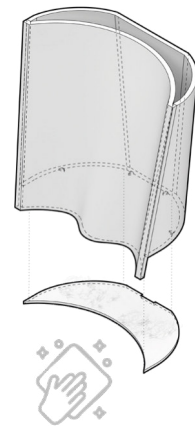
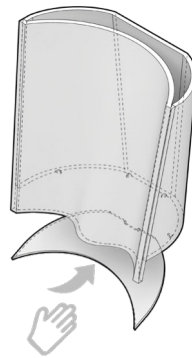
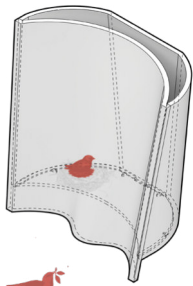

birds nesting inside these elements

birds leave their nest
the cap is removed for cleaning

cleaning and reinserting the cap
element ready for new birds to nest in

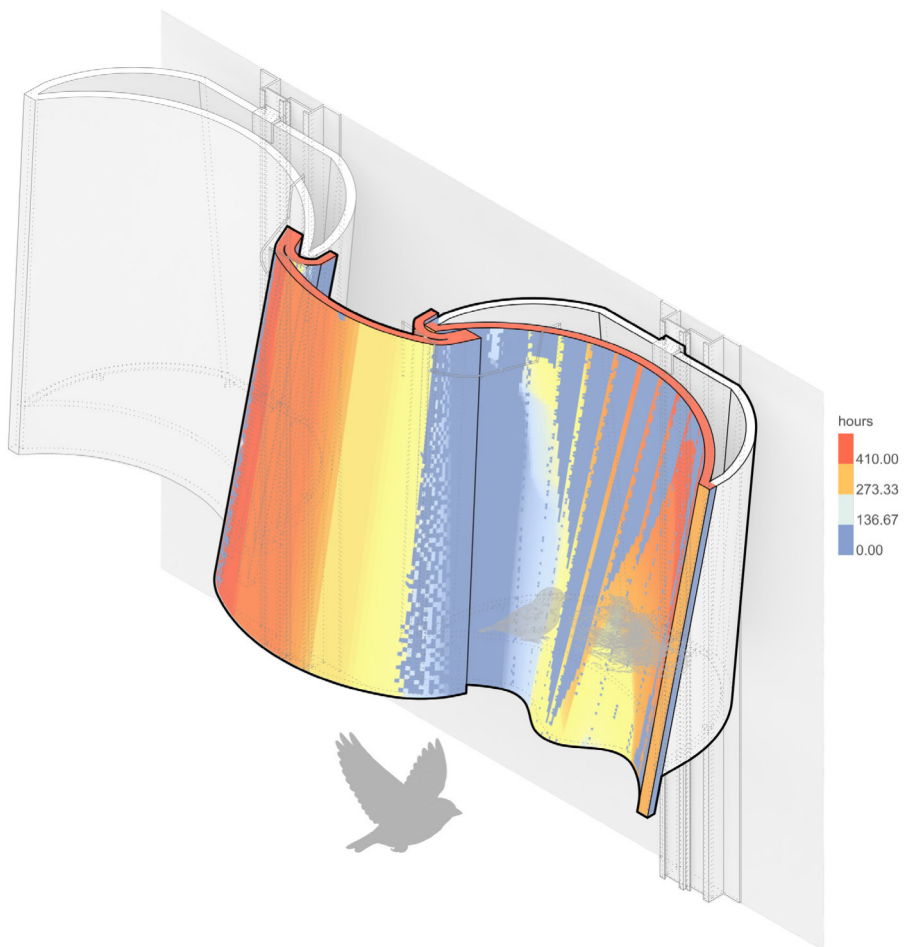



CohabiTile | facade implementation | Dalwigk Tower

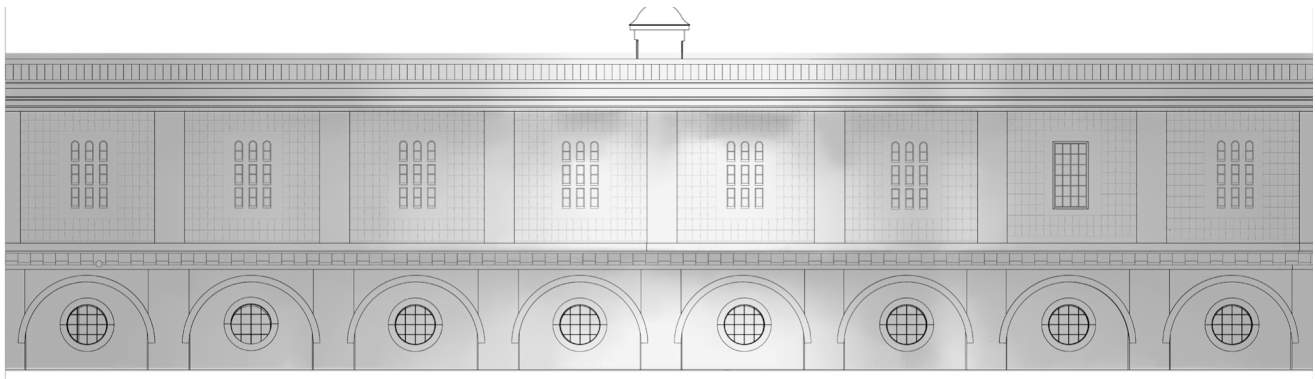

sun analysis

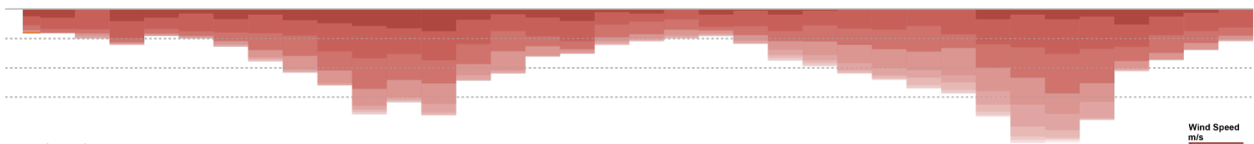

wind analysis



SÜD

OST

NORD

WEST

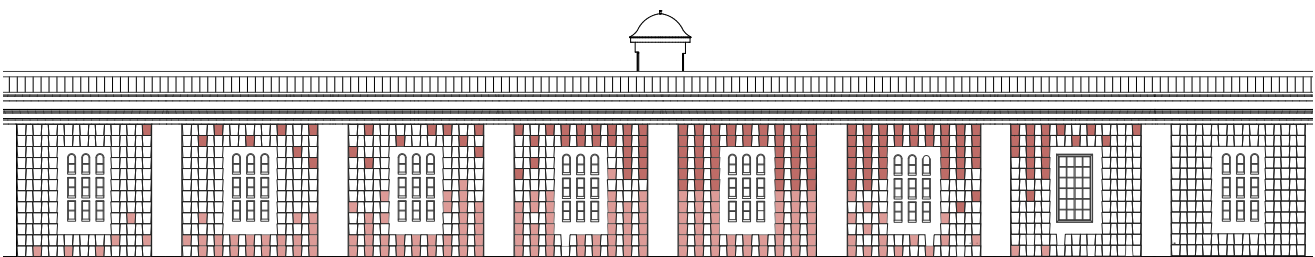

S

O

N

W

→ swifts north and west active in the evening

→ sparrow north and east active in the morning

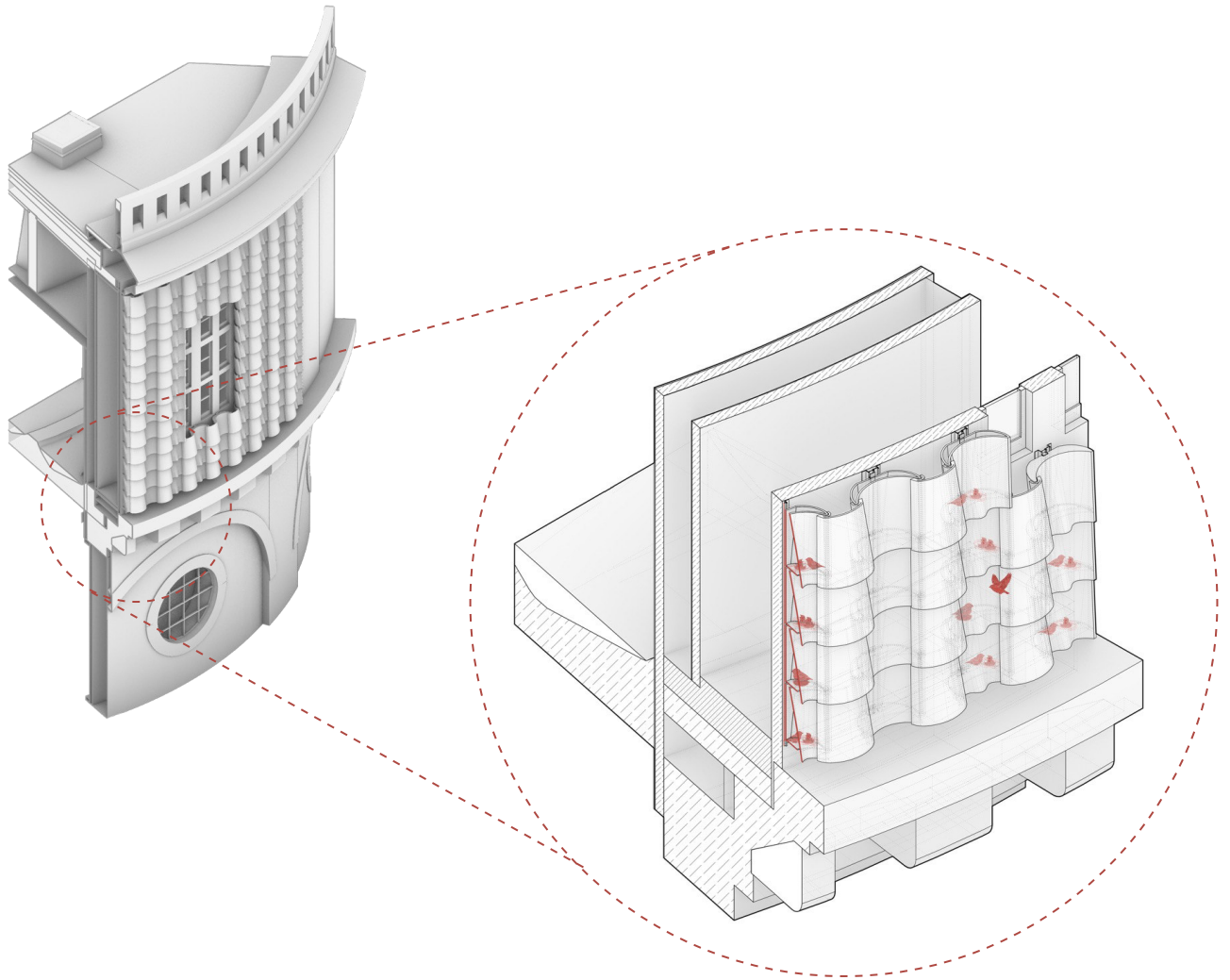

Substructure | Dalwigk Tower





facade system

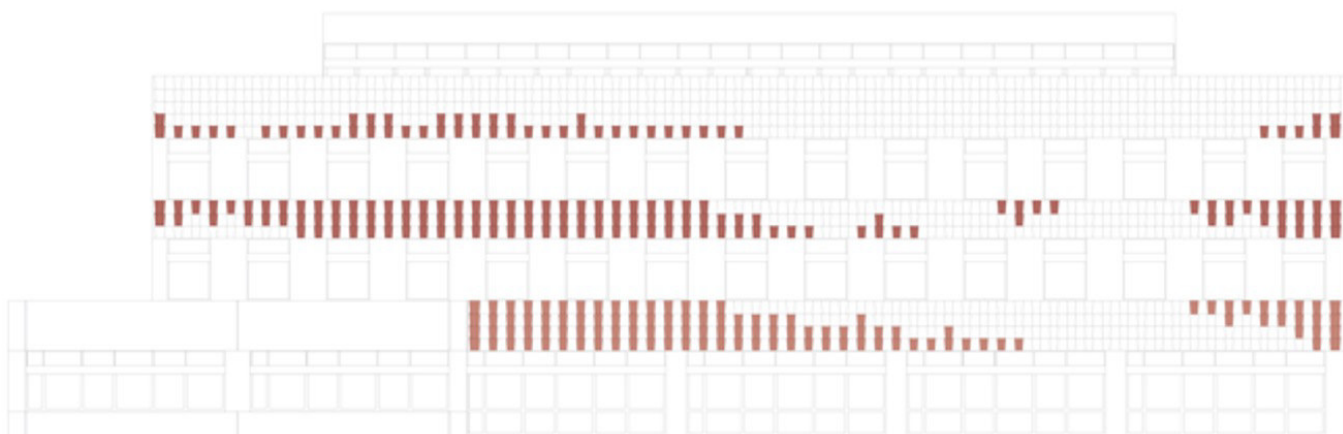
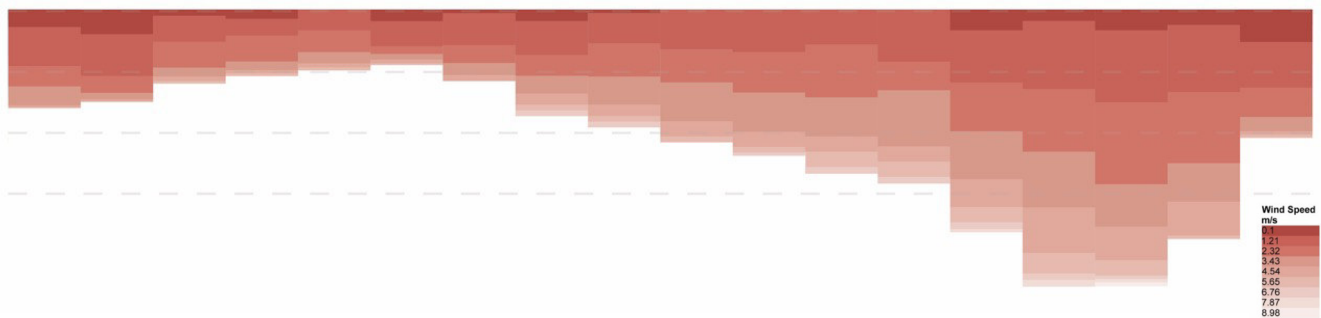
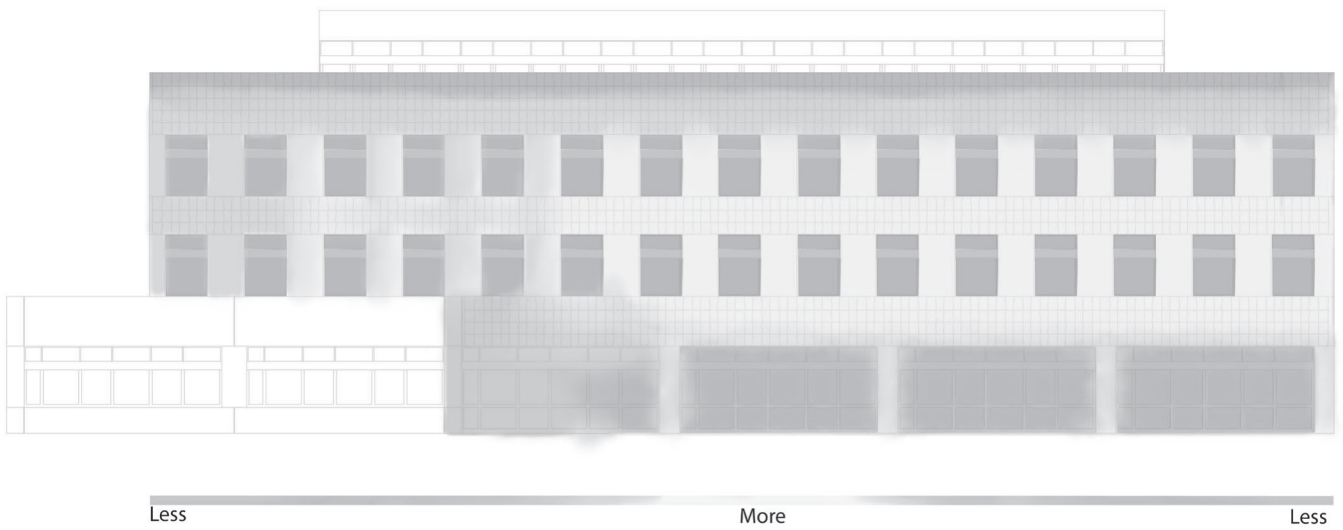

location of
nest elements



CohabiTiles

Nest and Flow.

CohabiShingles



Roof | example for CohabiShingles

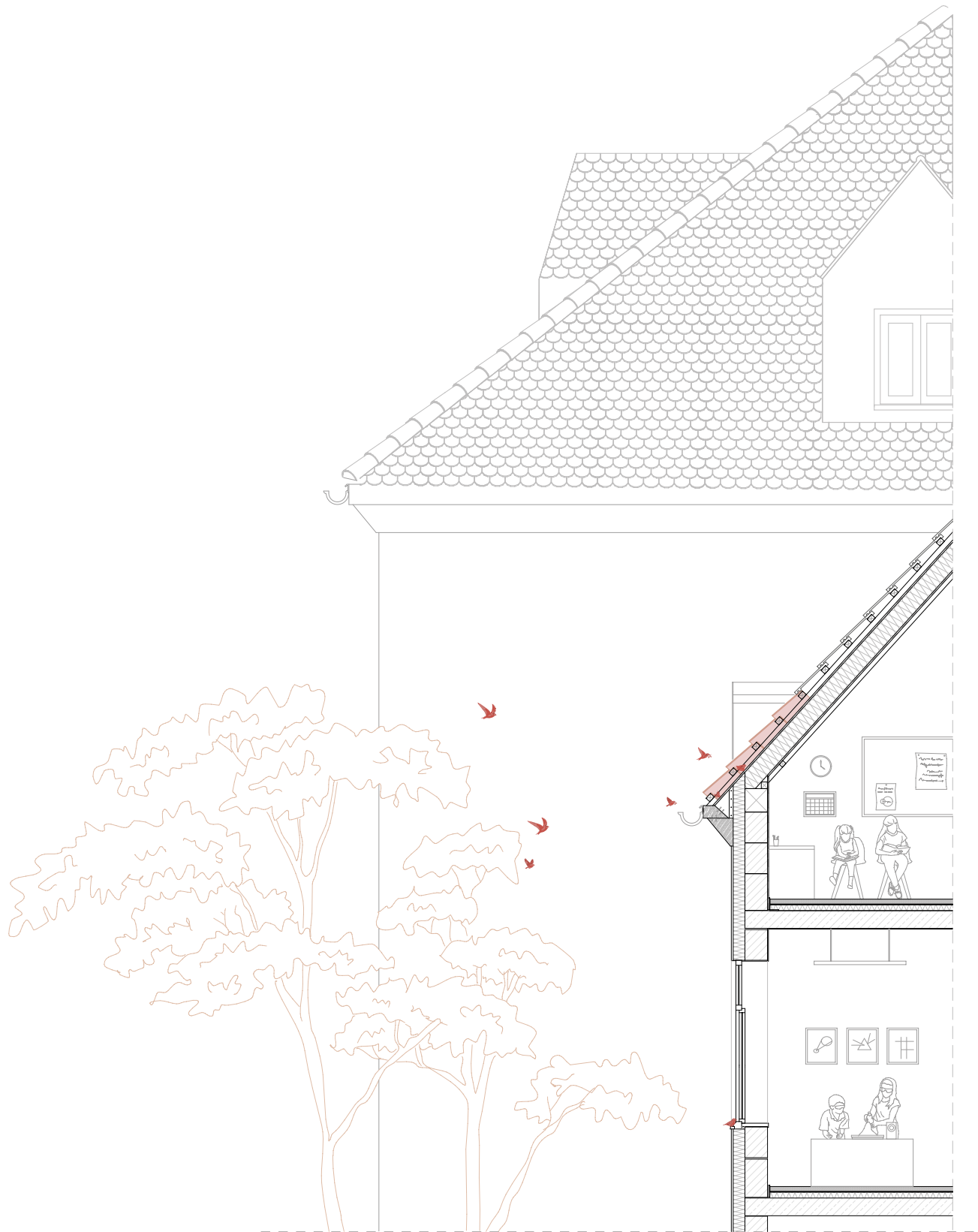

Roof | example for CohabiShingles | Section

CohabiTiles

Nest and Flow.

3D Printing Studies

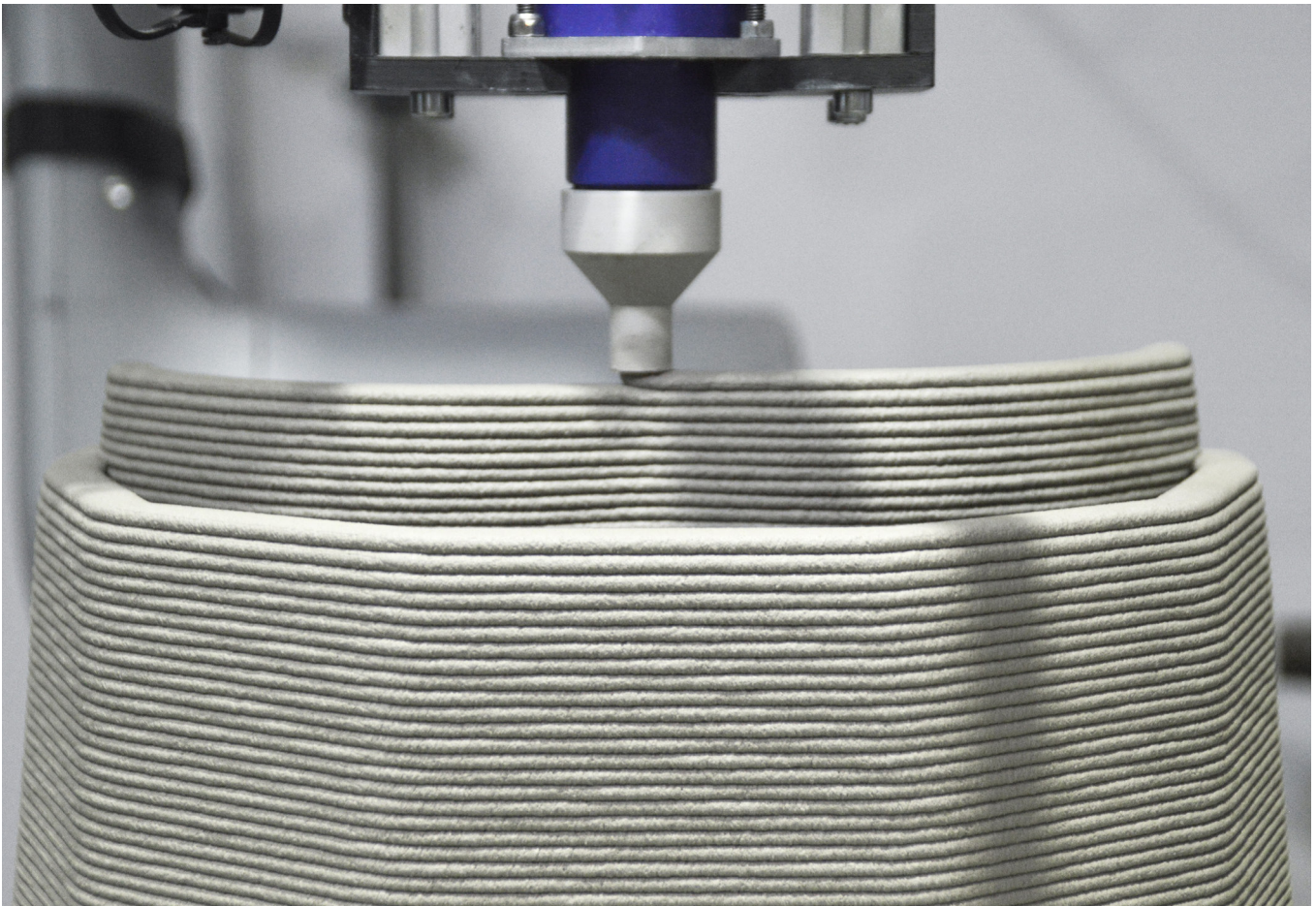
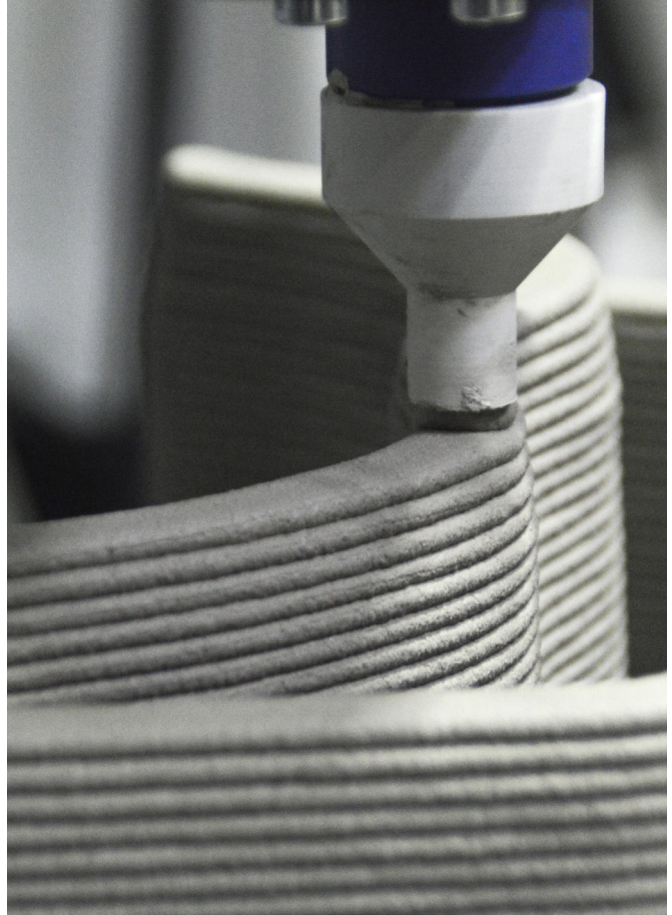
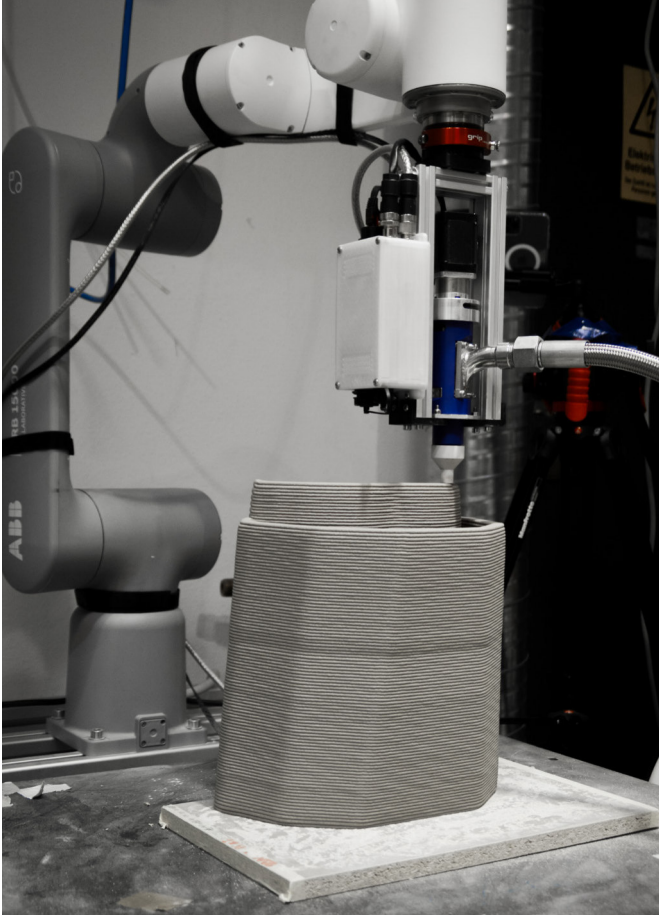

Printing overlapping part standing | Nest element

3D Printing studies

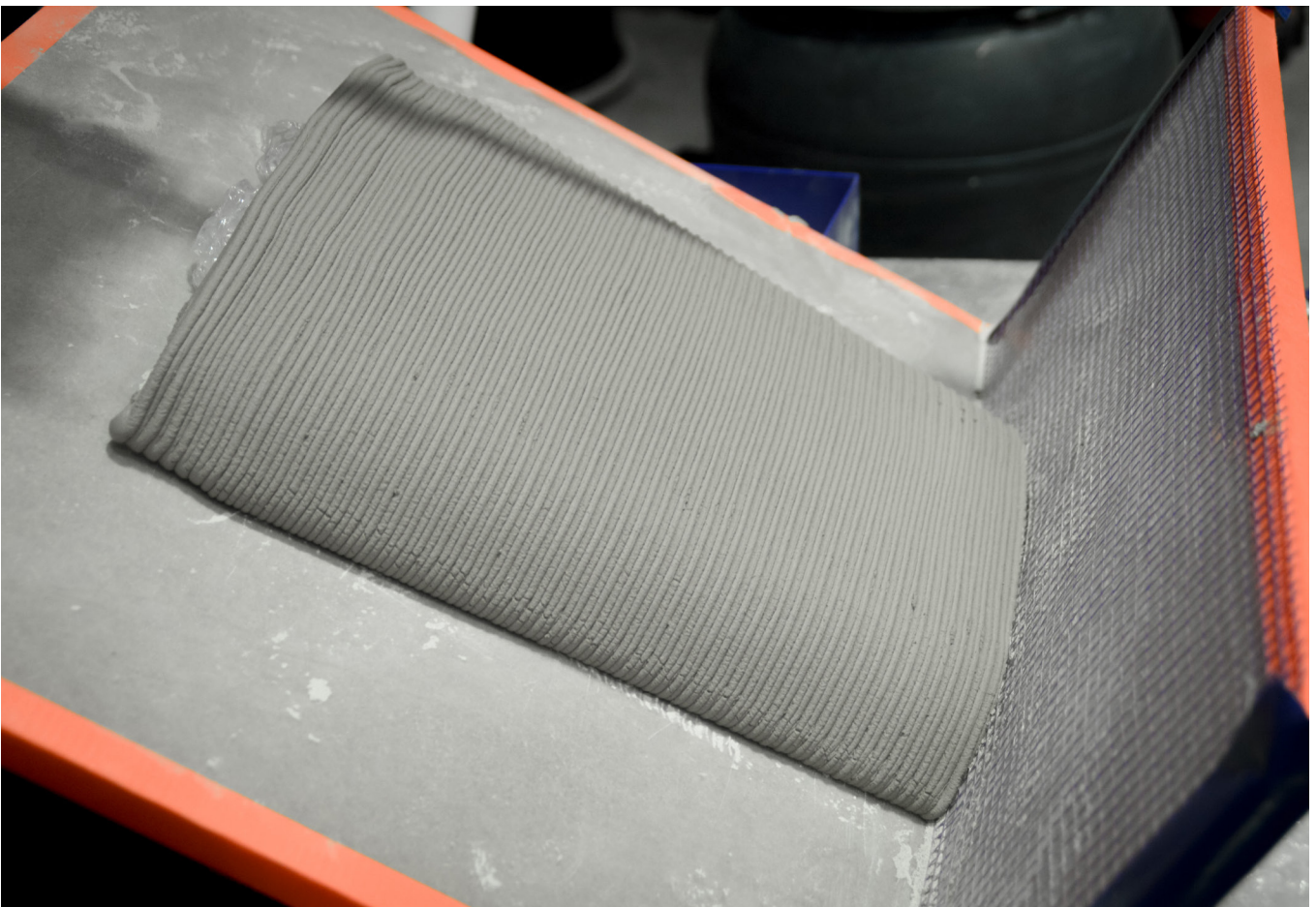

Printing standing | Flow element

CohabiTiles

Nest and Flow.

3D Printing Studies

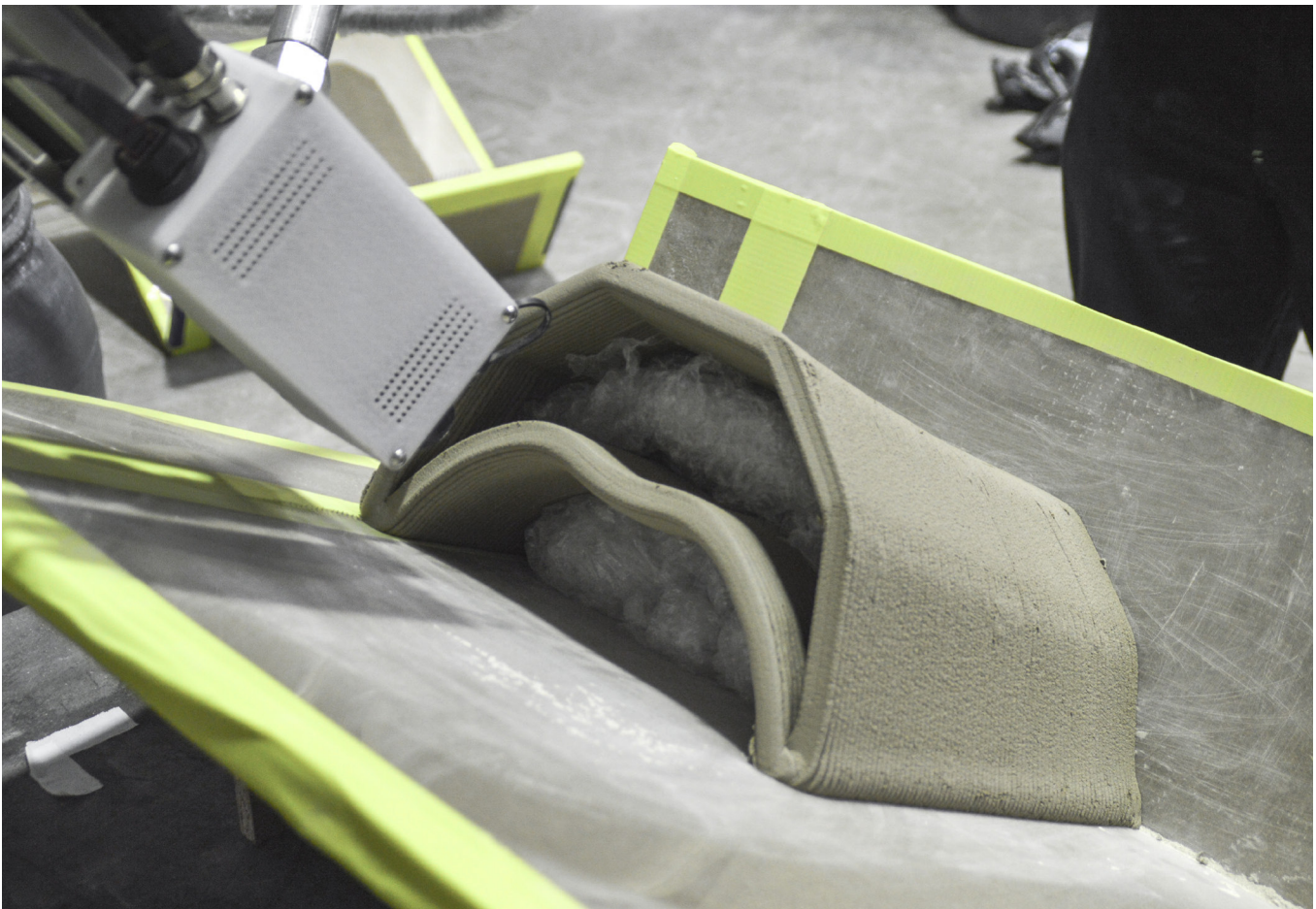
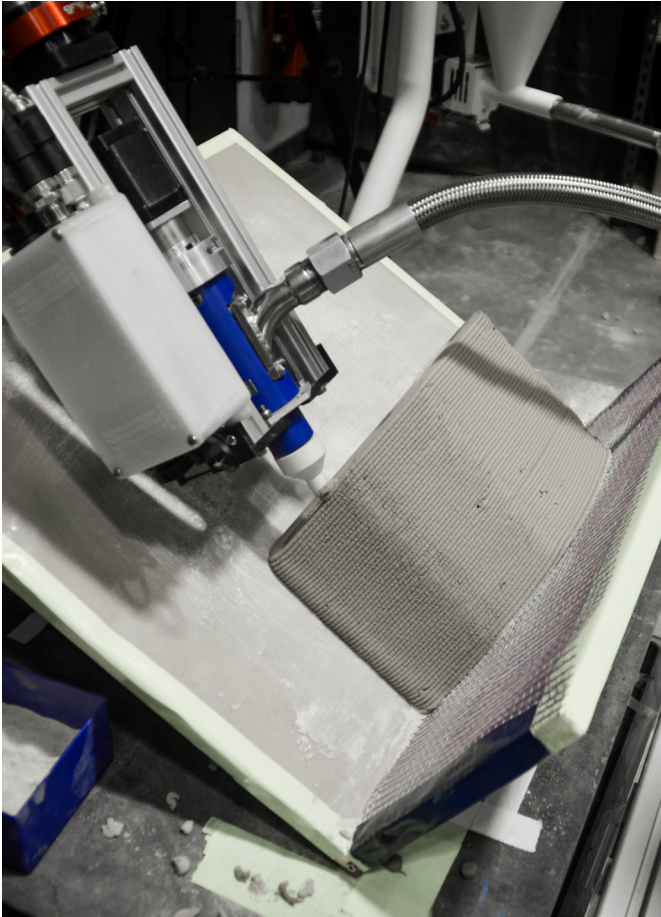

Printing with substructure 30 degree | Nest element



Presentation | Model